

Roadie HD+35K



Setup Guide

020-100394-06

Roadie HD+35K

USER MANUAL

020-100394-06

NOTICES

COPYRIGHT AND TRADEMARKS

© 2013 Christie Digital Systems USA Inc. All rights reserved.

All brand names and product names are trademarks, registered trademarks or trade names of their respective holders.

REGULATORY

The product has been tested and found to comply with the limits for a Class A digital device, pursuant to Part 15 of the FCC Rules. These limits are designed to provide reasonable protection against harmful interference when the product is operated in a commercial environment. The product generates, uses, and can radiate radio frequency energy and, if not installed and used in accordance with the instruction manual, may cause harmful interference to radio communications. Operation of the product in a residential area is likely to cause harmful interference in which case the user will be required to correct the interference at the user's own expense.

CAN ICES-3 (A) / NMB-3 (A)

이 기기는 업무용 (A 급) 으로 전자파적합등록을 한 기기이오니 판매자 또는 사용자는 이점을 주의하시기 바라며, 가정 외의 지역에서 사용하는 것을 목적으로 합니다.

GENERAL

Every effort has been made to ensure accuracy, however in some cases changes in the products or availability could occur which may not be reflected in this document. Christie reserves the right to make changes to specifications at any time without notice. Performance specifications are typical, but may vary depending on conditions beyond Christie's control such as maintenance of the product in proper working conditions. Performance specifications are based on information available at the time of printing. Christie makes no warranty of any kind with regard to this material, including, but not limited to, implied warranties of fitness for a particular purpose. Christie will not be liable for errors contained herein or for incidental or consequential damages in connection with the performance or use of this material.

The product is designed and manufactured with high-quality materials and components that can be recycled and reused. This

symbol  means that electrical and electronic equipment, at their end-of-life, should be disposed of separately from regular waste. Please dispose of the product appropriately and according to local regulations. In the European Union, there are separate collection systems for used electrical and electronic products. Please help us to conserve the environment we live in! Canadian manufacturing facility is ISO 9001 and 14001 certified.

GENERAL WARRANTY STATEMENTS

For complete information about Christie's limited warranty, please contact your Christie dealer. In addition to the other limitations that may be specified in Christie's limited warranty, the warranty does not cover:

- a. Problems or damage occurring during shipment, in either direction.
- b. Projector lamps (See Christie's separate lamp program policy).
- c. Problems or damage caused by use of a projector lamp beyond the recommended lamp life, or use of a lamp supplied by a supplier other than Christie.
- d. Problems or damage caused by combination of a Product with non-Christie equipment, such as distribution systems, cameras, video tape recorders, etc., or use of a Product with any non-Christie interface device.
- e. Problems or damage caused by the use of any lamp, replacement part or component purchased or obtained from an unauthorized distributor of Christie lamps, replacement parts or components including, without limitation, any distributor offering Christie lamps, replacement parts or components through the internet (confirmation of authorized distributors may be obtained from Christie).
- f. Problems or damage caused by misuse, improper power source, accident, fire, flood, lightning, earthquake or other natural disaster.
- g. Problems or damage caused by improper installation/alignment, or by equipment modification, if by other than Christie service personnel or a Christie authorized repair service provider.
- h. Problems or damage caused by use of a Product on a motion platform or other movable device where such Product has not been designed, modified or approved by Christie for such use.
- i. Problems or damage caused by use of a projector in the presence of an oil-based fog machine.
- j. For LCD projectors, the warranty period specified applies only where the LCD projector is in "normal use." "Normal use" means the LCD projector is not used more than 8 hours a day, 5 days a week. For any LCD projector where "normal use" is exceeded, warranty coverage under this warranty terminates after 6000 hours of operation.
- k. Image retention on LCD flat panels.
- l. Failure due to normal wear and tear.

PREVENTATIVE MAINTENANCE

Preventative maintenance is an important part of the continued and proper operation of your product. Please see the Maintenance section for specific maintenance items as they relate to your product. Failure to perform maintenance as required, and in accordance with the maintenance schedule specified by Christie, will void the warranty.

1: Introduction

1.1 Safety Precautions 1-1
 1.1.1 AC / Power Precautions 1-1
 1.1.2 Power Cords and Attachments 1-2
 1.1.3 Lamp Precautions 1-2

2: Installation and Setup

2.1 Projector Quick Setup and Installation 2-1
 2.2 Quick Setup 2-2
 2.2.1 Multiple Projector Operation 2-7
 2.3 Projector Position and Mounting 2-8
 2.3.1 Floor Mounting and Leveling 2-8
 2.3.2 Tilt and Special Orientations 2-9
 2.3.3 Hoist and Stack 2-10
 2.4 Installing Lens, Lamp, and Cooling 2-13
 2.4.1 Lens Installation 2-13
 2.4.2 Install First Lamp 2-15
 2.4.3 Liquid Cooling 2-16
 2.4.4 Ventilation 2-16
 2.5 Connecting Sources 2-16
 2.5.1 RGB Signals 2-18
 2.5.2 YPbPr Signals (Component Video) 2-19
 2.5.3 Composite Video 2-19
 2.5.4 Dual SD/HD-SDI 2-20
 2.5.5 Extra Video 2-21
 2.5.6 Optional Inputs 2-21
 2.6 Connecting the Ballast 2-21
 2.6.1 Configuring the Ballast for Incoming AC 2-22
 2.7 Basic Image Adjustment 2-23

3: Operation

3.1 Projector Basics 3-1
 3.1.1 Air Filter 3-1
 3.1.2 Breakers/Power Switches (ON/OFF) 3-1
 3.1.3 Control Panel (Rear of Projector) 3-2
 3.1.4 Handles 3-3
 3.1.5 Channels for FredFrame™ 3-3
 3.1.6 Security Locks 3-3
 3.2 Using the Built-In Keypad or Remote 3-3
 3.2.1 Built-in Keypad 3-3
 3.2.2 Standard IR Remote and Transmission 3-4
 3.2.3 Wired IR Remote 3-4
 3.3 Power-up Procedure/Checklist 3-5
 3.4 Power-down Procedure 3-6
 3.4.1 System Warnings/Errors 3-6

4: Troubleshooting

4.1 Projector Does Not Power ON..... 4-1

4.2 Lamp 4-1

 4.2.1 Lamp Does Not Ignite..... 4-1

 4.2.2 Lamp Suddenly Goes OFF..... 4-1

 4.2.3 Flicker, Shadows Or Dimness..... 4-1

 4.2.4 LampLOC™ Does Not Seem to Work 4-2

 4.2.5 LiteLOC™ Does Not Seem to Work 4-2

4.3 Calibrating the Lens Mount 4-2

4.4 Built In Keypad..... 4-2

 4.4.1 Projector ON, but No Backlight on Built-In Keypad..... 4-3

4.5 Image Displays..... 4-3

 4.5.1 Blank Screen, No Display of Image..... 4-3

 4.5.2 Severe Motion Artifacts 4-3

 4.5.3 Image Appears Vertically Stretched or ‘Squeezed’ into Center of Screen..... 4-3

 4.5.4 The Projector is ON, but There is No Display 4-3

 4.5.5 The Display is Jittery or Unstable..... 4-4

 4.5.6 The Display is Faint 4-4

 4.5.7 The Upper Portion of the Display is Waving, Tearing or Jittering..... 4-4

 4.5.8 Portions of the Display are Cut OFF or Warped to the Opposite edge..... 4-4

 4.5.9 Display Appears Compressed (Vertically Stretched) 4-4

 4.5.10 Data is Cropped from Edges 4-4

 4.5.11 Display Quality Appears to Drift from Good to Bad, Bad to Good 4-4

 4.5.12 Display has Suddenly Froze..... 4-4

 4.5.13 Colors in the Display are Inaccurate 4-5

 4.5.14 Display is Not Rectangular 4-5

 4.5.15 Display is “Noisy” 4-5

5: Specifications

5.1 Display 5-1

 5.1.1 Panel Resolution and Refresh Rate 5-1

 5.1.2 Achievable Brightness 5-1

 5.1.3 Achievable Contrast Ratio 5-1

 5.1.4 Colors and Gray Scale..... 5-1

 5.1.5 Gamma 5-1

5.2 Lenses 5-2

5.3 Inputs..... 5-2

5.4 Control 5-2

 5.4.1 Wired Remote 5-2

 5.4.2 Remote Control 5-2

 5.4.3 Ethernet 5-3

 5.4.4 RS-232 Serial Input..... 5-3

 5.4.5 RS-422 Serial Input..... 5-3

 5.4.6 GPIO Input..... 5-3

 5.4.7 Control Port (From Ballast) 5-3

| | |
|--|-----|
| 5.4.8 Ballast Ports | 5-3 |
| 5.5 Power | 5-4 |
| 5.5.1 Projection head | 5-4 |
| 5.5.2 7 kW 3-Phase Ballast (38-814001-51)..... | 5-4 |
| 5.6 Lamps | 5-5 |
| 5.7 Safety | 5-5 |
| 5.8 EMC Emissions | 5-5 |
| 5.9 EMC Immunity | 5-5 |
| 5.10 Operating Environment | 5-5 |
| 5.11 Non-Operating Environment | 5-6 |
| 5.12 Weight and Size | 5-6 |
| 5.12.1 Standard Dimensions | 5-6 |
| 5.13 Standard and Optional Components | 5-7 |
| 5.13.1 Standard (Sold with Product)..... | 5-7 |
| 5.13.2 Optional (Sold Separately)..... | 5-7 |

1 Introduction

Every effort has been made to ensure the information in this document is accurate and reliable; however, due to constant research, the information in this document is subject to change without notice.

This manual is intended for professionally trained operators of Christie high-brightness projection systems. These operators are qualified to replace the lamp and air filter, but should not attempt to install or service the Roadie HD+35K projector. Only qualified Christie technicians who are knowledgeable about the hazards associated with high-voltage, ultraviolet exposure, and the high temperatures generated by the projector lamp are authorized to assemble, install, and service the projector.

1.1 Safety Precautions

⚠ WARNING Never look directly into the projector lens or at the lamp. The extremely high brightness can cause permanent eye damage. For protection from ultraviolet radiation, keep all projector housings intact during operation. Protective safety clothing and safety goggles are recommended when servicing.

⚠ WARNING FIRE HAZARD! Keep hands, clothes, and all combustible material away from the concentrated light beam of the lamp.

⚠ CAUTION Position all cables where they cannot contact hot surfaces or be pulled or tripped over.

1.1.1 AC / Power Precautions

⚠ WARNING

- Use only the locking type AC power cord that is provided with the projector. DO NOT attempt operation if the AC supply is not within the specified voltage and power range.
- As a safety feature the projector is equipped with a three-wire plug with a third (grounding) pin. If you are unable to insert the plug into the outlet, contact an electrician to have the outlet replaced. DO NOT defeat the safety purpose of the grounding-type plug.
- DO NOT attempt operation if the AC supply is not within the rated voltage range, as specified on the license label.
- Disconnect projector from AC before opening any enclosure.
- The following applies to all countries except China:
 - A 30A maximum double pole, (UL listed for North America) wall circuit breaker is required for the 7kW switching ballast. It must be part of the building installation and easily accessible.
 - A 20A maximum double pole, (UL listed for North America) wall circuit breaker is required for the projector head. It must be part of the building installation and easily accessible.

⚠ CAUTION

- DO NOT allow anything to rest on the power cord. Locate the projector where the cord cannot be damaged by persons walking on it or objects rolling over it. Never operate the projector if the power cable appears damaged in any way.
- DO NOT overload power outlets and extension cords as this can result in fire or shock hazards.

1.1.2 Power Cords and Attachments

⚠ WARNING Connect the Christie-supplied line cord to your AC Supply. Do not substitute other cords. At the projection head, install the power cord retaining clip onto the power cord. The power cord and retaining clip provide a reliable ground and protect against electrical shock in the event of an electrical fault. This product can be connected to an IT power distribution system.

NOTICE: Use only the attachments and accessories recommended by Christie. Use of unapproved attachments or accessories may result in the risk of fire, shock, and personal injury.

1.1.3 Lamp Precautions

⚠ DANGER **EXPLOSION HAZARD!** Wear authorized protective safety gear whenever the lamp door is open! Never attempt to remove the lamp directly after use. The lamp is under significant pressure when hot and cold, and may explode, causing personal injury and/or property damage.

Protective Clothing

Never open the lamp door unless you are wearing protective clothing such as that included in a Christie Protective Clothing Safety Kit (P/N: 598900-095). Recommended protective clothing includes, but may not be limited to a polycarbonate face shield, protective gloves, and a quilted ballistic nylon jacket or a welder's jacket. **NOTE:** Christie's protective clothing recommendations are subject to change. Any local or federal specifications take precedence over Christie recommendations.

Cool the Lamp Completely

⚠ DANGER Lamp may explode causing bodily harm or death. Always wear protective clothing whenever lamp door is open or while handling lamp. Ensure those within the vicinity of the projector are also suited with protective clothing. Never attempt to access the lamp while the lamp is ON. Wait at least 15 minutes after the lamp turns OFF before powering down, turning off the breakers/power switches, disconnecting from AC and opening the lamp door.

2 Installation and Setup

This section explains how to install, connect and optimize the projector. Illustrations are graphical representations only and are provided to enhance the understanding of the written material.

2.1 Projector Quick Setup and Installation

Follow these steps for quick setup of the projector in a basic front-mount position.

⚠ WARNING Always power down and disconnect/disengage all power sources to the projector before servicing or cleaning.

⚠ CAUTION Disconnect AC Mains in case of an emergency by pulling the line cord from the wall or the projection head.

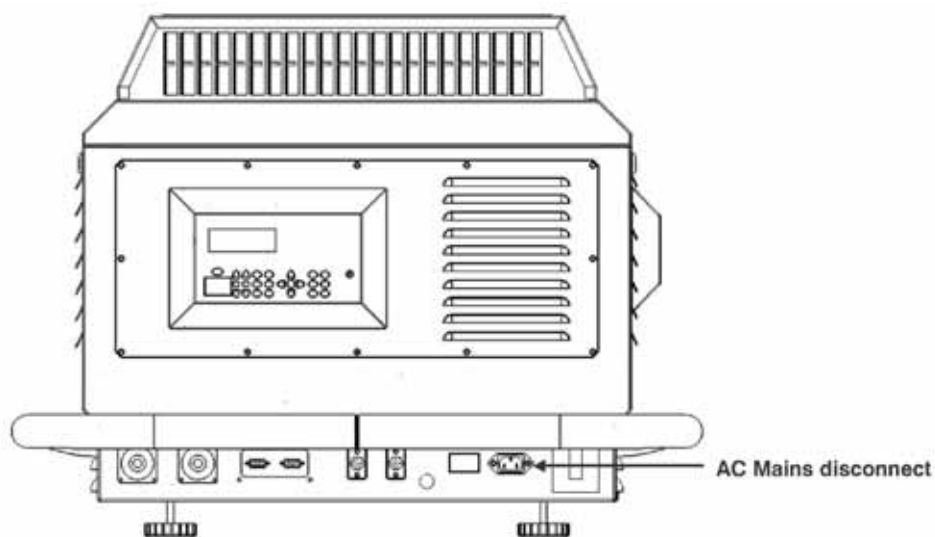

2.2 Quick Setup

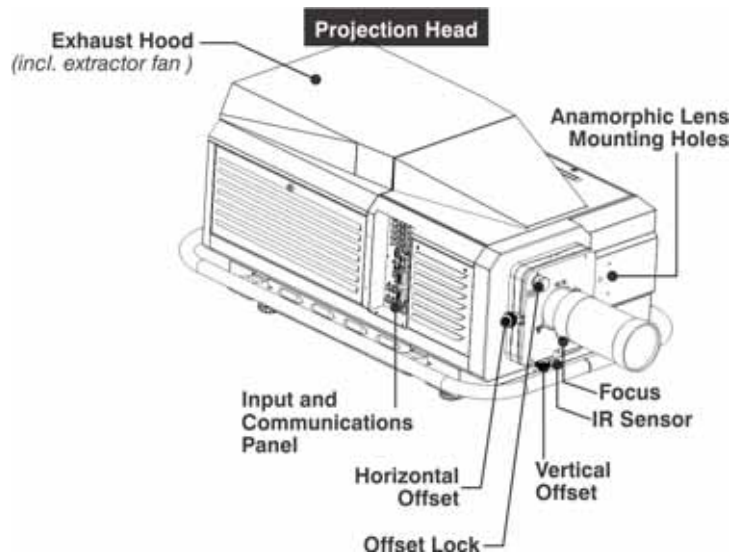

1. Position the projector at an appropriate throw distance and vertical position from the screen. Make sure that the projector is level from side-to-side, and is not inverted.
2. Securely fasten the ring terminal at the end of the earth wire to the building ground.
NOTE: A Christie accredited service technician must verify that the earth wire is properly grounded, prior to powering up the projector or connecting to the lamp ballast.
3. Install the lens and the lamp. See [Section 2.4 Installing Lens, Lamp, and Cooling](#).
4. Connect an input source to a port on the input panel on the side of the projector.
5. Install the lamp ballast so the 4 cables reach the rear of the projection head.
6. Connect the lamp ballast to the projector:

- a. Connect the 2 DC power cables and 2 communication and control cables to the rear of the projector.

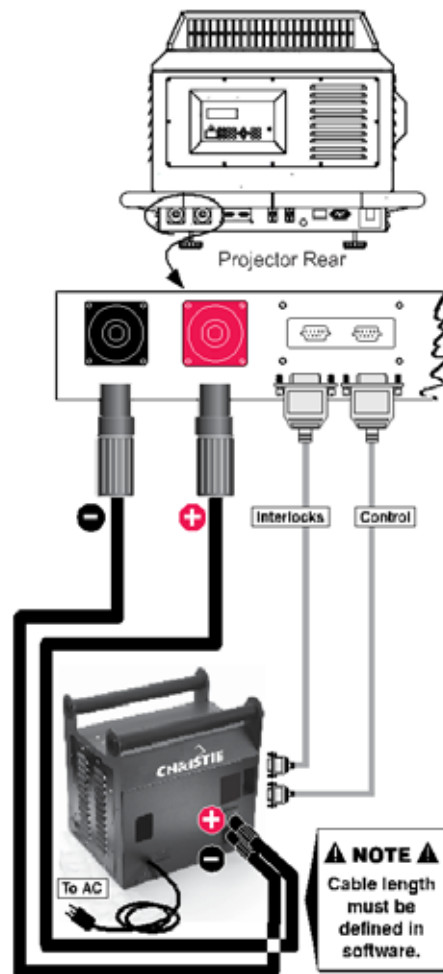

Figure 2-1 Connecting the Lamp Ballast to the Projector

- b. Connect the lamp ballast power cord to an AC supply.

NOTE: Before you connect the ballast power cord to AC power, a Christie accredited service technician must verify the ballast power cord plug and input power range switch match the line voltage at the installation location.
- c. Confirm the status lights on the lamp ballast are on and that the adjacent voltmeter displays the correct AC level for your location. **NOTE:** For China models the main ballast breaker must be in the ON position (the Lamp Breaker can be Off).
- d. Turn the ballast breakers/power switches on.

NOTE: The ballast's internal fan is the only indication whether or not the breakers/power switches is ON. Lights on the ballast indicate only that the ballast is plugged in.

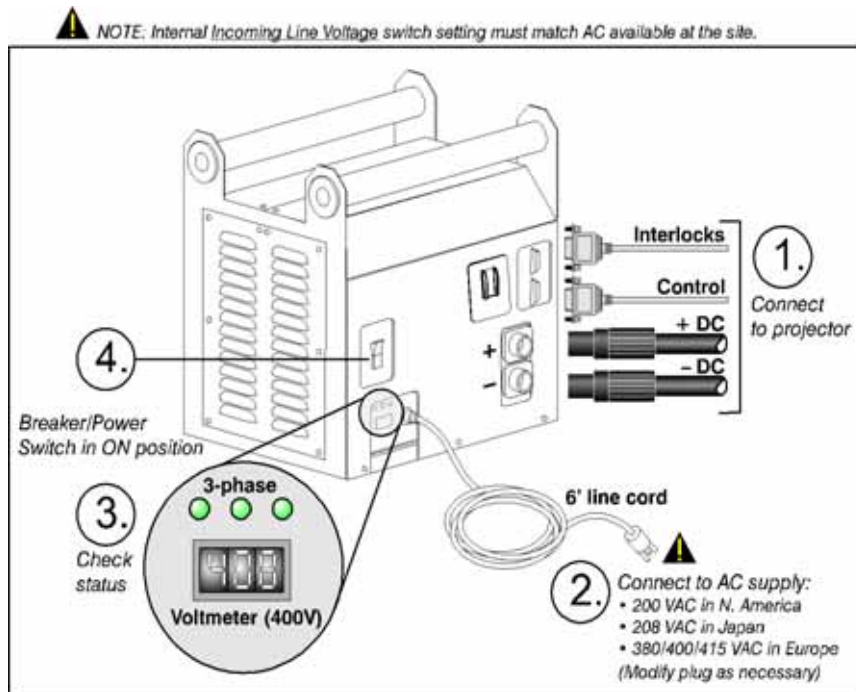

FIGURE 2-2 LAMP Ballast Connection and Power Switch

7. Connect the projector power cord to an AC supply and turn breaker switch on.

The projector is now in standby mode. The voltmeter displays the incoming voltage, the PROJ. STATUS light is yellow, and the light engine compartment fans are running.

NOTE: Use only the locking type AC power cord that is provided with the projector.

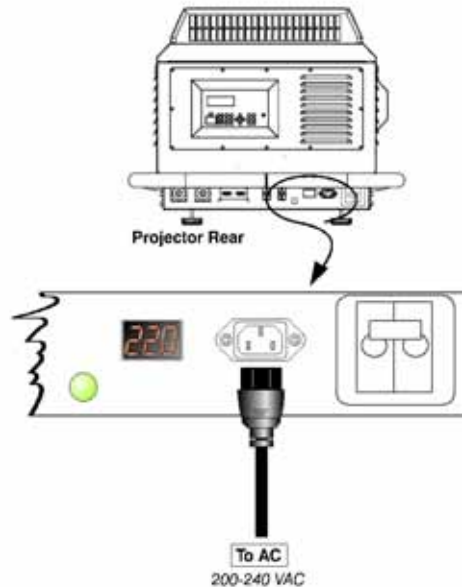

Figure 2-3 Connecting the Projection Head to AC

⚠ WARNING Do not operate the projection head if the AC level is not within the specified voltage and power range.

8. Set the lamp type:

⚠ WARNING Explosion hazard. Keep the projection head off until you define the lamp type installed.

- a. Press **MENU**.

- b. Enter the lamp password with the projector keypad.

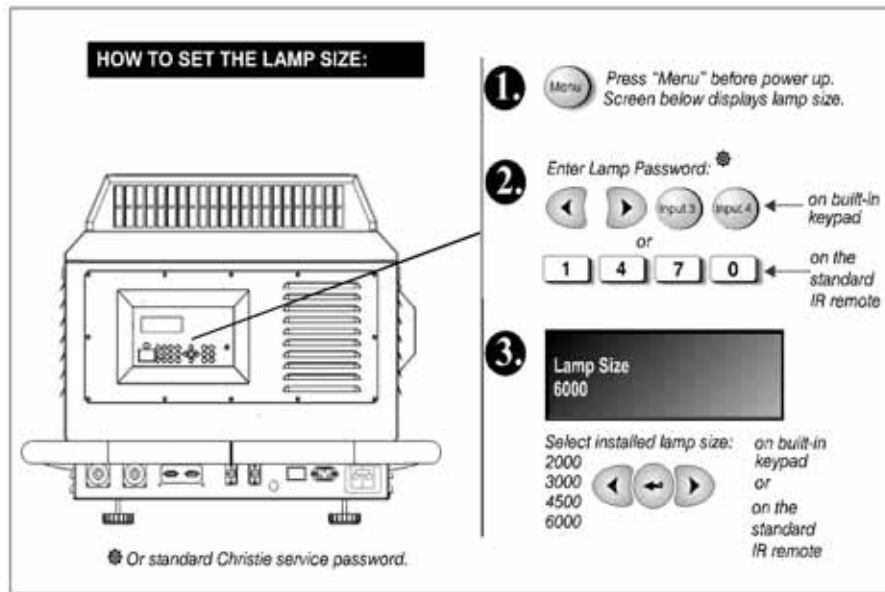

Figure 2-4 Setting the Lamp Type

- Use the up and down arrows to select a lamp size.
 - Enter the lamp size listed on the Lamp Installed label located above the lamp door.
9. Turn the projector on, and ignite the lamp:
- On the keypad, press **POWER** and then **UP**.
- OR-
- On the remote, press **POWER** and then **UP**. The PROJ. STATUS light on the rear of the projector illuminates.
- Let the projector warm up for a minimum of 10 minutes.
 - On the remote or the projector keypad, press the **INPUT** key (1-6) to display the image for the input source.
 - Use the remote to adjust the brightness, contrast, and gamma settings.
 - Press **FOCUS** on the remote or the projector keypad to focus the image.
 - Press **ZOOM** to increase or decrease image size (not available with fixed 0.8:1 and 1:1 lenses).
 - Press **LENS SHIFT**, and the **ARROW** keys to move the image.
 - Open the Lamp menu and set the **Cable Length** (m) setting to the length of the high-voltage DC cables that run from the lamp ballast to the projection head. This setting ensures that adequate voltage reaches the lamp. If you are using the same projector in multiple, temporary installations, you must update this setting every time you install the projector.

2.2.1 Multiple Projector Operation

⚠ DANGER Fire Hazard! To avoid a fire hazard for multiple projector operation, make sure the high current DC Leads and interlocks/control cables are correctly connected between the Lamp Power Supply (LPS) and its corresponding projector. DO NOT cross-connect one set of cables from one LPS to a second projector.

Repeat *Section 2.2 Quick Setup* for each additional projector in multiple projector operations. Christie recommends that the units MUST NOT be operated until the installation has been verified as correctly connected. Use this diagram to determine if the connections between the projector head and LPS are correct:

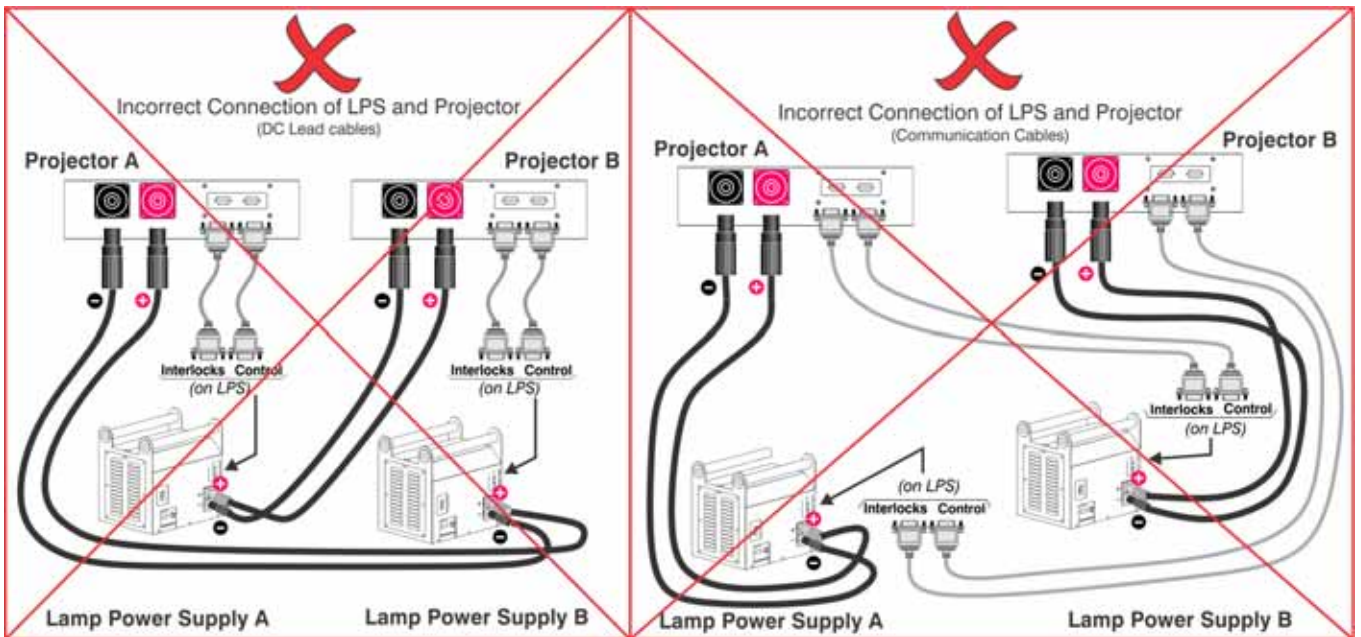
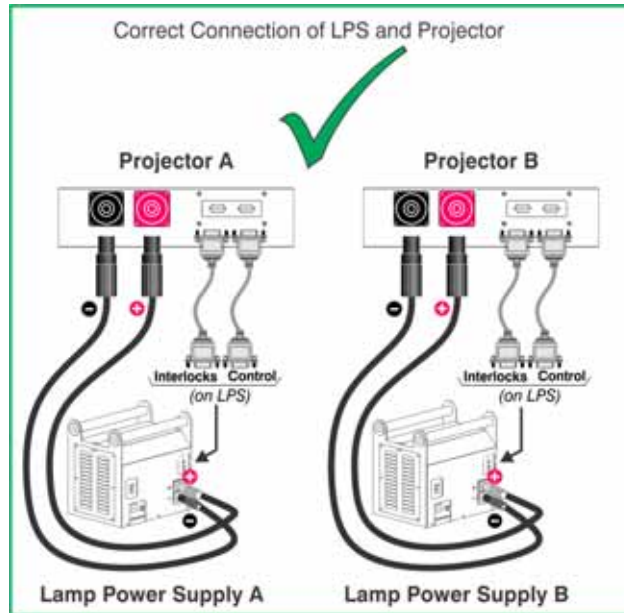

To confirm that the cross-connection has not occurred, power only one LPS and projector pair at a time. DO NOT power multiple LPS and projector heads simultaneously. Before you turn on multiple projectors, you must confirm each projector head and lamp power supply are connected and operating correctly.

2.3 Projector Position and Mounting

Installation type, the available screen, and ambient lighting all affect where the projector should be positioned. In addition, both throw distance (the distance between the projector and screen) and vertical position (the height of the projector in relation to the screen) must be determined for every new installation. Both depend on the screen size and lens type you are using. Ensure the room can accommodate the required location of the projector for the chosen screen size.

For more information about the Roadie HD+35K lens throw ratio calculations, see the *Roadie HD+35K Throw Distance Technical Document* available on the Christie website, *PN 020-100395-XX*.

2.3.1 Floor Mounting and Leveling

For front projection without suspending, mount the projector on a strong supporting structure or cart. If using a mobile cart, avoid sudden stops, force, and uneven surfaces that may cause the top-heavy cart to lurch and overturn.

Make sure your mounting structure is reasonably level, and then adjust one or more projector feet as necessary to fine-tune.

⚠ WARNING Do not invert this projector.

Adjust the Feet

For installations on a floor or suitable supporting structure, a single projection head should rest firmly on its feet. To adjust the height and level of the projector, extend or retract the feet by rotating them.

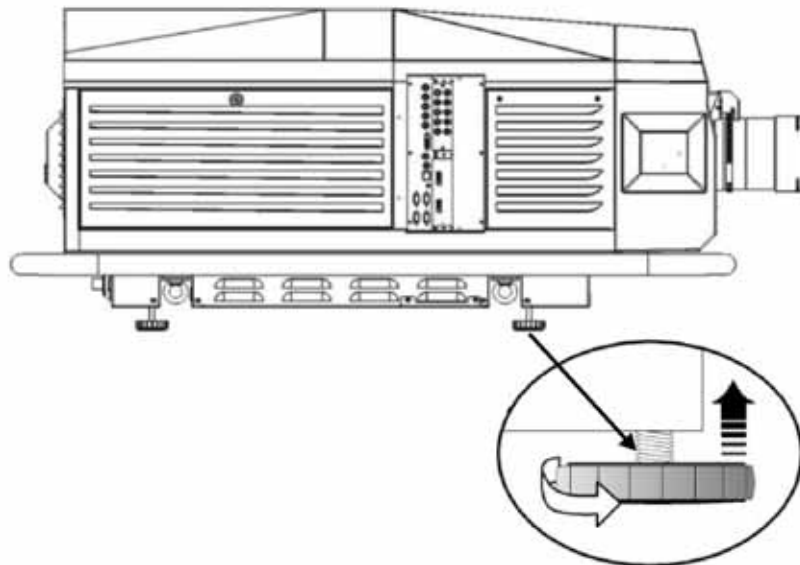

2.3.2 Tilt and Special Orientations

Tilt

For any installation, you can tilt the projector up, down or side-to-side as much as 15 degrees. This limit ensures safe lamp operation and proper position of the liquid cooling reservoir in the projector.

⚠ WARNING Tilt only as shown.

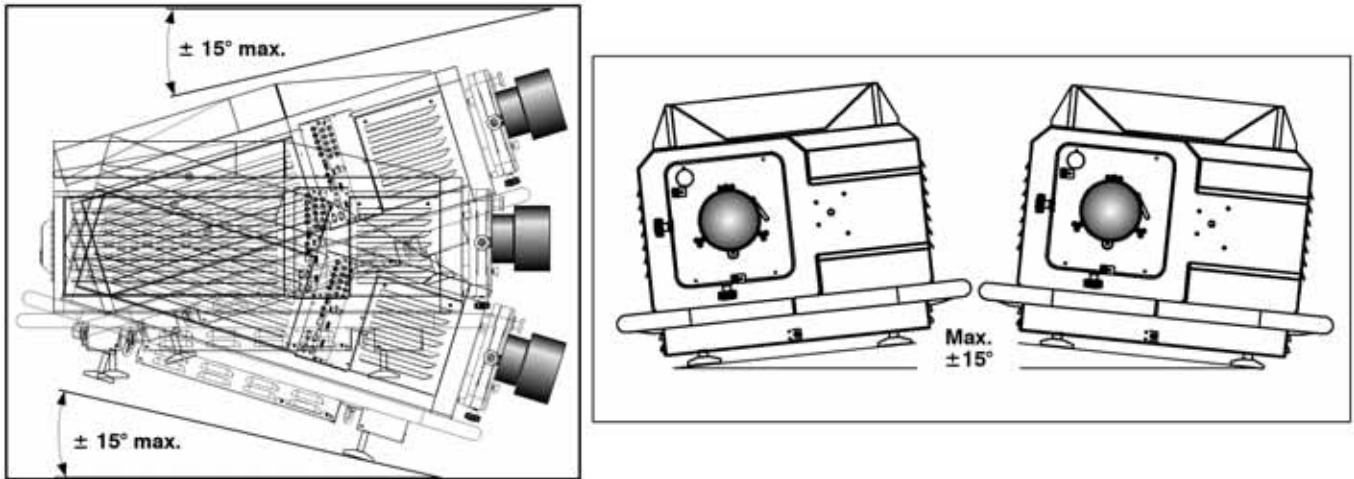

Portrait Mode

The Christie portrait upgrade kit (*113-112105-XX*) is required when installing Christie projector models *113-003104-01* or *38-DCP400-XX* in portrait mode. The Christie portrait upgrade kit is not required for model *113-003104-02* and later projectors. When you install the Roadie HD+35K projector in portrait mode, suspend it in a Christie rigging frame (*38-814007-XX*) so the intake and exhaust vents are not obstructed.

NOTE: You must perform a lamp alignment after installing a projector in portrait mode.

⚠ WARNING For portrait mode, install the lens in the orientation shown below. Failure to orient the lens correctly can damage the projector. The maximum tilt angle is ±15 degrees.

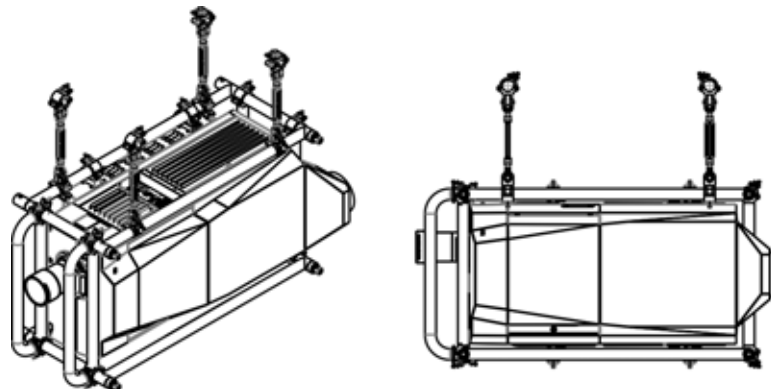

Special Orientations

Since this projector cannot be inverted or tilted beyond 15 degrees, all installations are typically front or rear mounted, and requires the orientation of the “Front” or “Rear” image to be set in the **Configuration > Image Orientation** menu option.

2.3.3 Hoist and Stack

For most installations, you will likely have to safely lift or hoist this projector-or a stack of two projectors-into place. Keep in mind the following critical safety guidelines for all handling of the projector.

Carry/Move the Projection Head

Four or more people can lift and hand-carry one projection head a short distance using the handles or the optional FredFrame™, if installed. **Never** carry a stack of projectors.

Hoisting/Rigging a Single Projection Head

A single projection head can be hoisted and/or suspended using its handles, a set of rigging clamps (113-102101-XX), and appropriate rigging and safety cables. If desired, the lamp ballast can also be flown from its integral rigging bars. To hoist, stack or “fly” a stack of projectors you must use the optional FredFrame™. See *Using the FredFrame™* described below.

Read the following safety warning before hoisting/ rigging ONE projection head. See 020-100133-XX for more information.

- ⚠ DANGER** Any overhead suspension used **MUST** be suitably rated for the weight of the projector. The projector’s weight is 435 lb / 197.3 kg.
- ⚠ WARNING** Maximum load rating of the projector's handles is 435 lb / 197.3 kg. Use straps and/or cabling with load capacity adequate for the total projector and handles when lifting/hoist. **Never** exceed the load rating specified.
- ⚠ WARNING** **Never** try to lift or carry more than one projector at a time.
- ⚠ WARNING** Remove the projection lens before hoisting/rigging.

When hoisting/rigging a single projector using its handles, do the following:

1. Remove the projection lens. See *2.4.1 Lens Installation*.
2. Clamp the 4 rigging clamps to the projector's handles staying within the assigned rigging zones. See *Figure 2-5* and *Figure 2-6*, and allow a minimum of 12 inches between clamps for proper stability. Do not tighten the cross bolt of the clevis arms to ensure the rigging clamp can swivel freely.
NOTE: *Symmetrical placement of the clamps on each side of the handles is strongly recommended.*
3. Secure the other end of each clamp to the primary support structure.
4. Secure the projector with an additional two safety straps. Using one safety strap per cross beam, route the strap through the bottom 2 eyebolts and bring them up, and around the outside of the handles.
See *Figure 2-6*.

5. Install the projection lens and secure it with the safety ring and tether strap as described in *Section 2.4 Installing Lens, Lamp, and Cooling*.

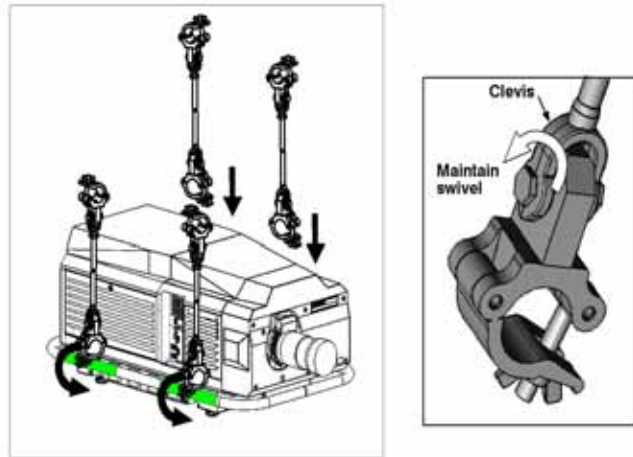

Figure 2-5 Securing Clamps to Projection Head

⚠ WARNING 1) A minimum of 4 rigging clamps are required for a single projector. 2) Always use redundant safety straps/cables. 3) Observe load ratings and all local applicable codes.

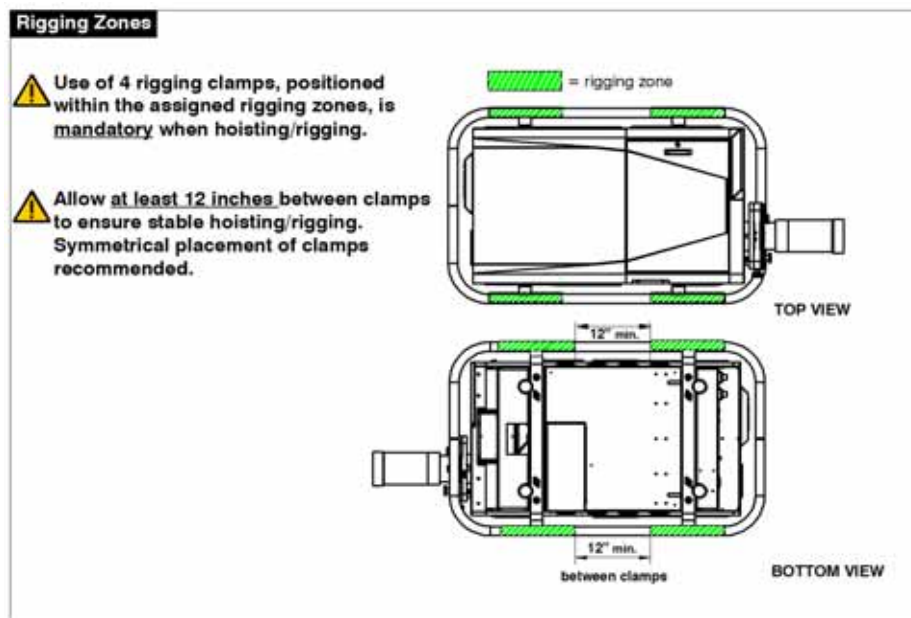

Figure 2-6 Rigging Zones on Projector Handles

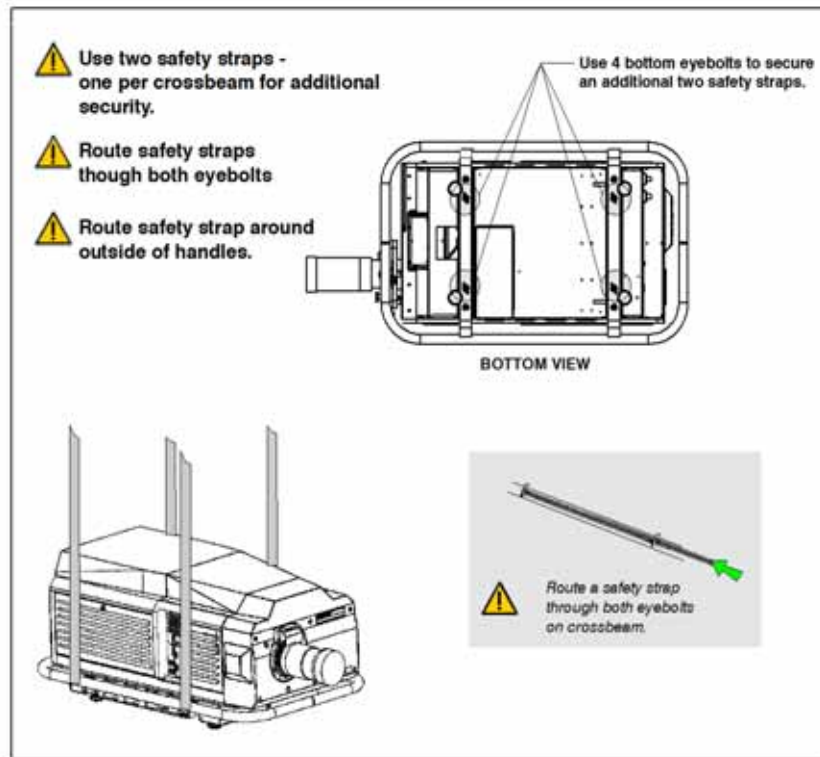

Figure 2-7 Using Safety Straps

Using the FredFrame™

To hoist, stack and/or “fly” projectors using the optional FredFrame™ (PN 38-814007-XX), you must first remove the handles and properly secure each projection head within a FredFrame™. Then using appropriate rigging clamps (included with FredFrame™ or 113-102101-XX), you can raise and/or suspend the projector assembly. If desired, the lamp ballast can also be hoisted and flown from its integral rigging bars. Follow the instructions provided with the FredFrame™ kit.

⚠ WARNING 1) Use straps and/or cabling with load capacity adequate for the total projection head and frame weight. 2) Remove the lens before hoisting. 3) Critical safety means to never exceed the Load Rating specified in the FredFrame™ Stacking and Rigging Kit instructions.

See the complete instructions for using the FredFrame™. These include all installation instructions as well as mechanical adjustment procedures for proper image alignment.

Using a Fork Lift

⚠ WARNING Do not attempt to use a forklift without first installing the forklift rails on the bottom of the FredFrame™, otherwise the base of the projector may crush and damage internal components.

Strong extruded rails that mount to the bottom of the FredFrame™ accommodate forks from a forklift, and are mandatory for this method of transport. Do not lift the projection head with equipment unless the FredFrame™ and forklift rails are installed. The projector's handles must be removed when installing the FredFrame™. Follow the instructions provided with the FredFrame™ kit.

Stacking

To stack two projection heads together, you must first secure each head within a FredFrame™, and then secure all corners of the frames together using 4 stacking pins (provided). Do not stack more than 2 projection heads together, and do not attempt to move stacked projectors without proper transport equipment. See the instruction provided with the FredFrame™ Kit for stacking.

2.4 Installing Lens, Lamp, and Cooling

It is recommended that the lens and lamp installation be handled at the last possible moment to ensure that no damage is done to the projector due to movement.

2.4.1 Lens Installation

Primary Lens

1. Remove the rear lens cap from the lens.
2. Rotate the lens clamp to the OPEN position.
3. Orient your primary lens with its UP label at the top and fully insert the assembly straight into the lens mount opening all the way back, without turning.

NOTES: 1) Ensure that the Zoom connector is fully engaged. 2) When installing the lens, ensure that the lens is *NOT* inserted at an angle, as this can cause damage. 3) Ensure that the lens is fully back to seat properly within the lens mount.

IMPORTANT! *The following steps are necessary to ensure your safety and that the lens does not fall out.*

4. Lock the lens assembly in place with the lens clamp **DOWN**.
5. For added security, tether the lens to the projector by wrapping it around either the handle or FredFrame™ if flown. This step is not required if the projector is floor-mounted.

⚠ DANGER In the event a lens is dropped, the lens tether and clamp assembly may become stressed, and therefore must be replaced before continuing its use. Failure to do so could result in injury or death.

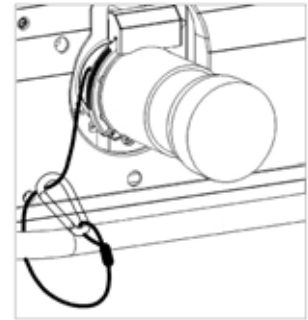

Figure 2-8 Tether Lens to Projector

6. Remove the front lens cap.
7. Calibrate the lens. See [Figure 2-9](#). For more information, see [Section 3, Operation](#) in the *Roadie HD+35K User Manual*.

⚠ CAUTION Lens calibration must be performed each time a new lens is inserted or after performing manual lens mount adjustments. To calibrate the lens, select the **Configuration > Diagnostics and Calibration > ILS Calibration > Reference Calibration** option from the Main menu. This is critical to the projector functioning properly. Failure to do so could result in damage to the lens mount, the projector, or the projection lens.

To calibrate the lens, select the **Configuration > Diagnostics and Calibration > ILS Calibration > Reference Calibration** option from the Main menu. This allows the lens to find the center points of each axis (focus, zoom, horizontal, and vertical), the end stops, and other motion parameters.

NOTE: *Failure to calibrate the lens can cause damage to the lens mount.*

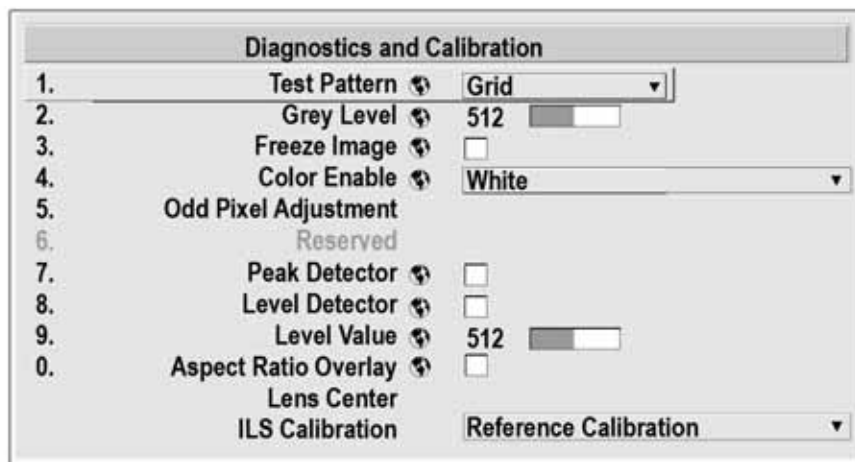

Figure 2-9 Diagnostic and Calibration Menu

Lens Center Command

This command moves the lens horizontal and vertical motion to the center of travel.

NOTES: **1)** *The lens seals the projection head, preventing contaminants from entering the area of main electronics. Never attempt to operate the projector without a lens installed. During transport and installation, install a lens plug.* **2)** *Always re-install a lens in its previous “UP” orientation, otherwise boresight may require re-adjustment.*

Anamorphic Lens Installation (Optional)

NOTE: *The optional anamorphic lens mount is required for use of the 1.26x anamorphic lens, producing 2.39:1 “scope” images. However, the lens mount cover must be removed when installing the anamorphic lens mount and in order to use the MALM.*

If the anamorphic lens is used, it is recommended that you add the lens and its mount before final leveling or making any adjustments (i.e. boresight, etc.). Install only for those installations requiring full-size 2.39:1 “scope” display (mostly side-masking screens) obtained by optically stretching a pre-squeezed image.

1. Install the anamorphic lens mount on the projector.

At the front of the projector, install the anamorphic lens mount hardware as described in the instructions provided with the *Christie Anamorphic Lens Mount Kit*.

2. Install the 1:26x anamorphic lens.

Clamp the 1.26x anamorphic lens mount in place, following the instructions provided with the anamorphic lens mount kit.

2.4.2 Install First Lamp

⚠ WARNING **Explosion Hazard. Wear authorized protective clothing whenever the lamp door is open.**

1. Open the lamp door and remove lamp cooling compartment door.

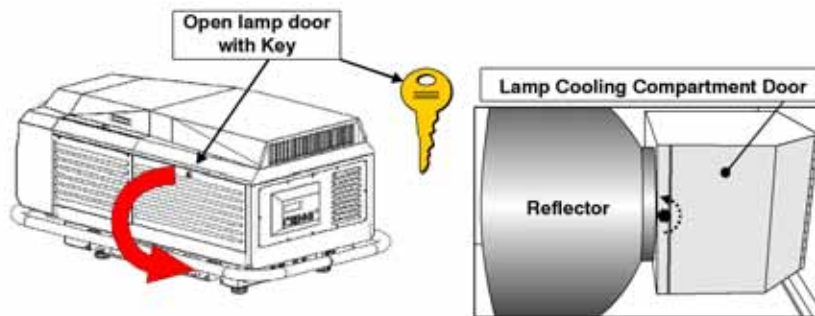

Figure 2-10 Open Lamp Door and Cooling Compartment

2. Install one of the following lamps in the projection head, depending on your model and site:

- 2.0 kW*
- 3.0 kW*
- 4.5kW*
- 6.0 kW*

NOTE: *3-phase ballast is required.*

* Available as CDXL (maximum performance) or original CXL.

See [Section 5 Specifications](#).

1. Check lamp cradle (Anode end) location for your lamp.
 - For 4.5 or 6.0 kW lamps, the lamp cradle should use the holes farthest from the reflector (factory default).
 - For 2.0 or 3.0 kW lamps, use the holes closest to the reflector.
2. Install lamp.

See [Section 4.2 Replacing the Lamp and Filter](#) in the *Roadie HD+35K User Manual*.

NOTES: **1)** Observe all warnings, and wear protective clothing and shielding. **2)** Do Not forget to properly mark the “Lamp Installed” label on the lamp door to indicate current lamp size.

2.4.3 Liquid Cooling

During operation, a closed loop of flexible tubing circulates liquid coolant from a small reservoir to critical electronic components located near the front of the projection head. The coolant (a 50/50 mix of distilled water and ethylene glycol) should fill approximately half of the reservoir to ensure adequate circulation. The reservoir, which is located in the Igniter compartment, is factory-filled and does not require draining for transit. Check regularly.

2.4.4 Ventilation

Vents and louvers in the projector covers provide ventilation, both for intake and exhaust. Never block or cover these openings. Do not install the projector near a radiator or heat register, or within an enclosure.

2.5 Connecting Sources

Sources connect to the Input Panel located on side of the projector closest to the lens. See [Figure 2-12](#).

The upper left corner (**INPUT 1**) typically accepts an RGB signal from an external analog RGB source, or it can also be used for YPbPr signals. Just beneath these BNCs, the DVI-I connector (**INPUT 2**) accepts digital or analog display signals from a computer. An HDMI to DVI adapter cable accepts digital signals from a Blu-Ray or DVD player. Connect analog composite video at **INPUT 3** or S-video at **INPUT 4** from devices such as VCRs or DVD players. At **INPUT 5**, connect serial digital YCbCr (4:2:2) or compatible SMPTE signals (note this module can be moved to **INPUT 6**, if desired).

There are also several optional interfaces available for connecting other sources, these interfaces slide into either Input 5 or Input 6, and can be removed or installed while the projector is running.

NOTE: Some Input options are not available with some projector models.

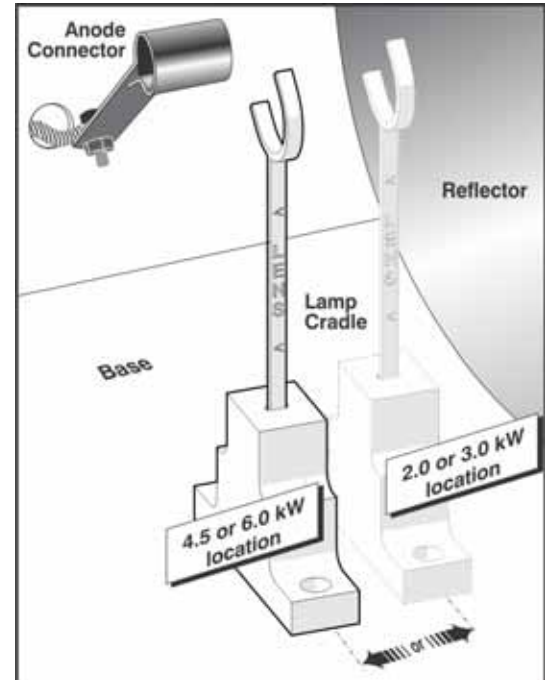

Figure 2-11 Move cradle back for 2.0 or 3.0

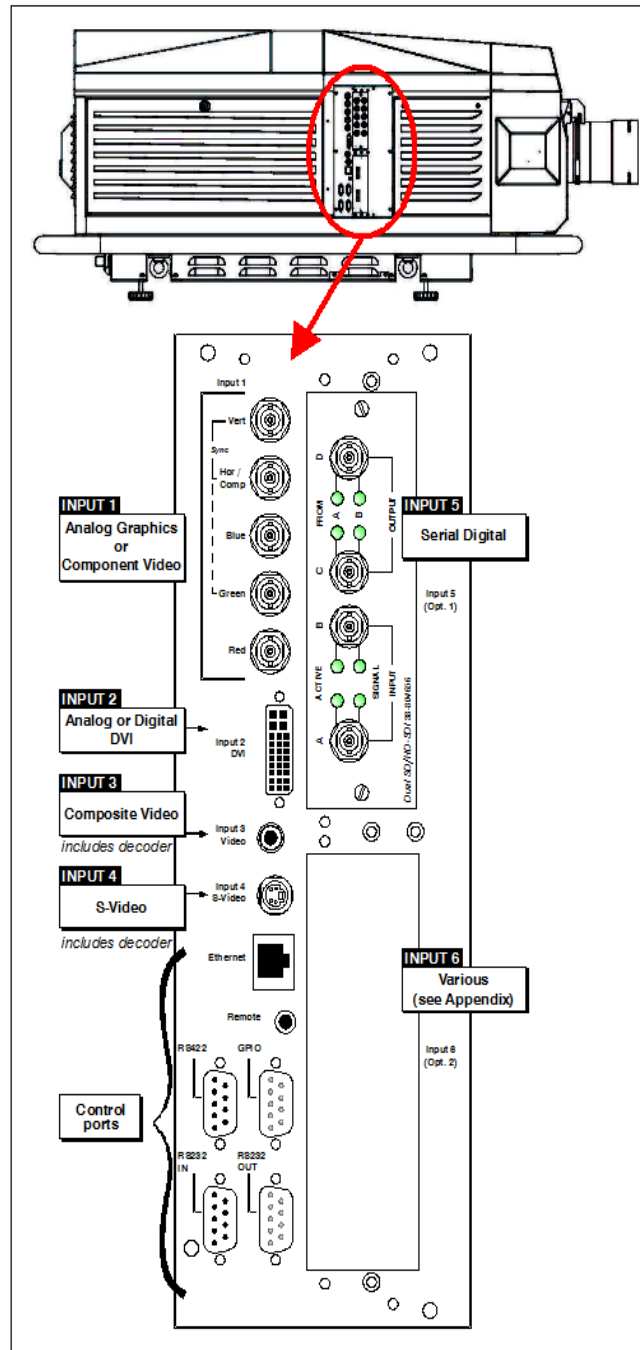

Figure 2-12 Roadie HD+35K Input Panel

NOTES: 1) See *Section 5 Specifications* for details regarding compatible inputs. 2) Use only high-quality shielded cables for all connections.

2.5.1 RGB Signals

INPUT 1 consists of five BNCs (connectors) for linking to a variety of sources. The typical connection would be to an RGB source such as a PC, Mac, DEC, Sun, SGI and others. This projector supports multiple sync types with RGB signals: sync-on-green, composite sync, and separate H and V syncs.

NOTE: Depending on your source, you may need a custom adapter cable with BNC connectors at the projector end and a different type of connector at the other (such as a 15-pin “D” connector for some computer sources). Contact your dealer for details.

Connect the **SYNC** BNC input(s). Then connect the red, green and blue source outputs to the **RED**, **GREEN**, and **BLUE** BNCs on the **INPUT 1** panel. If the source uses sync-on-green, only the red, green, and blue connections are required. If the source provides a composite sync output, connect it to the **SYNC** input labeled **HOR/COMP**. If the source provides separate horizontal and vertical sync outputs, connect horizontal sync to the **SYNC** input labeled **HOR/COMP** and connect vertical sync to **SYNC** input labeled **VERT**. Connecting an RGB Source.

NOTES: **1)** If for some reason the projector fails to recognize a signal as an RGB signal, specify this Color Space option within the Image Settings menu. See **Section 3.6.3 Image Settings Menu** in the **Roadie HD+35K User Manual**. **2)** To connect YPbPr signals—such as from DVDs or analog HDTV sources—to **INPUT 1**, use the red, green and blue BNCs as described in YPbPr Signals (below). **3)** This input does not route to the decoder and cannot be used for Composite Video or S-Video.

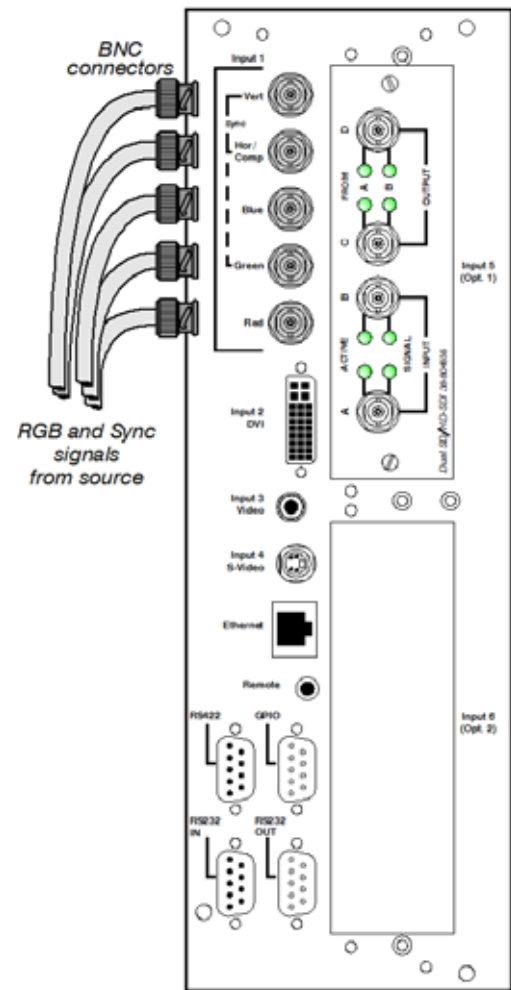

2.5.2 YPbPr Signals (Component Video).

Connect a YPbPr signal (component video) to **INPUT 1** or **INPUT 2**, as shown.

NOTES: 1) *If, for some reason, the projector fails to recognize a YPbPr signal, specify this Color Space option within the Image Settings menu. See Section 3.6.3 Image Settings Menu in the Roadie HD+35K User Manual. 2)* *Do not connect digital component signals (known as YCbCr) to INPUT 1 or INPUT 2. Use the appropriate optional digital interface installed in INPUT 5 or 6 only.*

2.5.3 Composite Video

INPUT 3 and **INPUT 4** provide simultaneous connection of both a composite video source (**INPUT 3**) and an S-Video source (**INPUT 4**). See Figure 2-13.

NOTE: *Unlike previous Christie projectors, composite video and S-Video cannot connect to any other locations on the input panel. Connect as shown in Figure 2-13.*

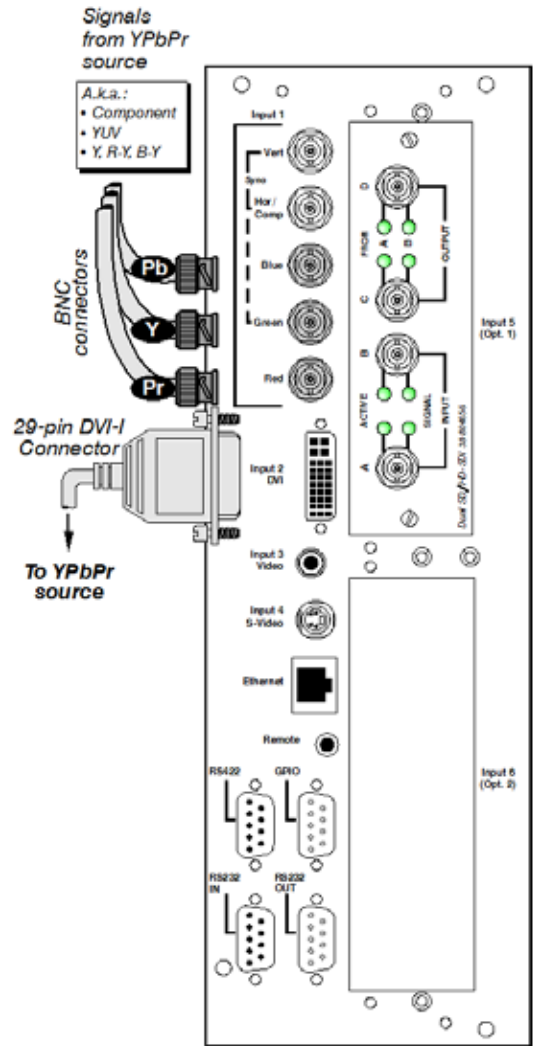

2.5.4 Dual SD/HD-SDI

Christie's Dual SD/HD-SDI module is standard with this projector and factory-installed in the first option slot (labeled **INPUT 5**). Its loop-through capability enables incoming serial digital data (HD format) to be tiled across multiple screens, creating vast “mega resolution” displays. Alternatively, the multiple outputs can be overlapped for extra-bright displays, or simply distributed to additional projectors for multiple screens of the same image.

The module accepts one or two independent standard- or high-definition serial digital inputs, decodes them for processing in the main electronics of the projector, and outputs 10-bit RGB/YCbCr 4:2:2 video. Either input can be set as the active primary or secondary part of a Picture-in-Picture (PIP) display, and either input can be looped through to one (or both) of the module's BNC outputs.

NOTE: Selection of these inputs is described in Section 3.2 Using the Built-In Keypad or Remote.

Connect a compatible SMPTE 292M or SMPTE 259M-C source(s) to one or both of the inputs located on the left side of the module. The module automatically detects the standard at each input and configure itself accordingly for correct termination of the signal. The module also detects and supports dual link 292M for SMPTE 372M video standards.

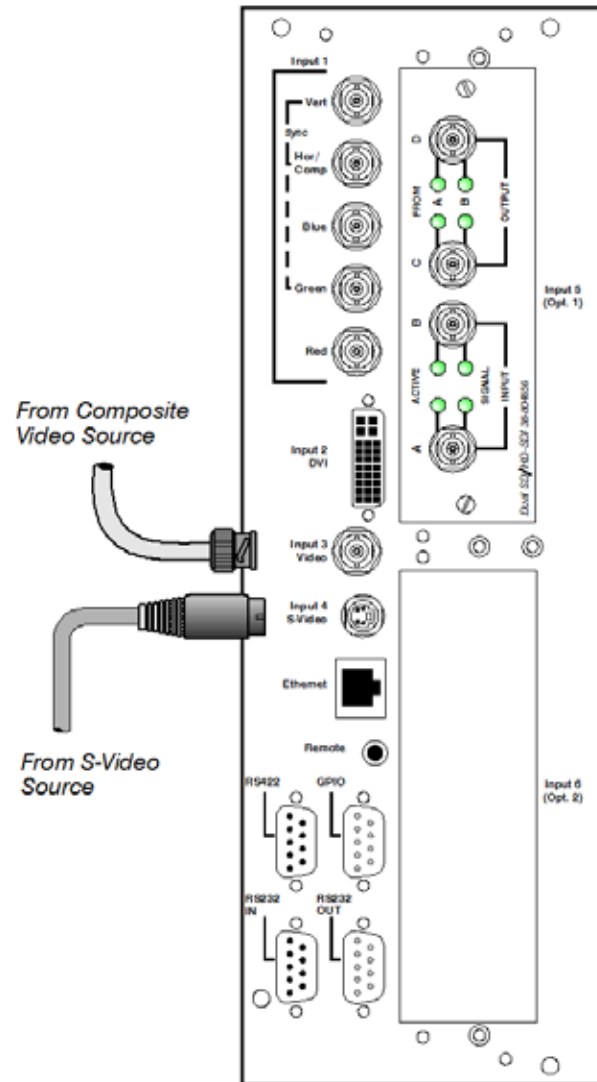

Figure 2-13 Connecting Composite Video and/or S-Video

2.5.5 Extra Video

If you want to use an extra video source in addition to the video source(s) connected at **INPUT 3** or **INPUT 4** connect either a Composite or S-video source to **INPUT 1** as shown.

NOTES: **1)** Do not simultaneously connect Composite and S-video to **INPUT 1**. **2)** You can switch between video sources connected at **INPUT 1** and **INPUT 3** or **INPUT 4**.

2.5.6 Optional Inputs

Optional input modules allow you to increase your total number of inputs and/or accommodate different signal types, whether analog or digital. Install in the areas labeled **INPUT 6** or (if available) **INPUT 5**. These interfaces include:

- DVI Input Module
- Dual SD/HD-SDI Module (supplied as standard in this projector)

For even more sources, connect a third-party switcher to the RS-232 IN port, or, if RS-422-compatible, to any of the two RS-422 ports.

Older input cards not listed may be supported by the Roadie HD+35K.

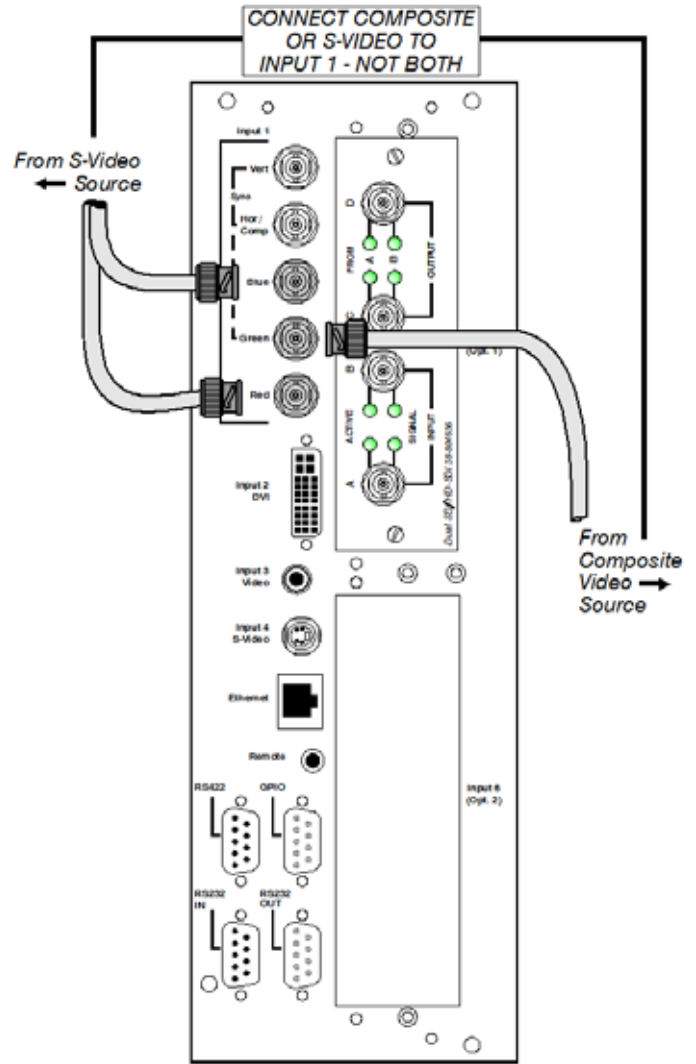

Figure 2-14 Connect Extra Video

NOTES: **1)** Connect analog HDTV signals directly to **INPUT 1** or to any other "RGB" input module installed-the optional HDTV Input Module used in earlier projectors is not needed or recommended. **2)** See **Appendix D: Optional Input Modules** in the **Roadie HD+35K User Manual** for a brief description of each interface.

2.6 Connecting the Ballast

Do not connect the ballast to AC until the projection head and ballast are connected to each other.

⚠ WARNING Connect the ballast to the projector **FIRST**, then connect the ballast to AC.

2.6.1 Configuring the Ballast for Incoming AC

AC power levels vary from region to region throughout the world, with 400 VAC common in some countries (such as those in Europe and Asia), and 200 VAC common elsewhere (such as in North America and Japan). To accommodate both possibilities, the ballast includes an internal **Input Power Range Switch** for toggling to the level of AC available at the installation site, i.e. either 200 or 400 VAC. The line cord plug must also match.

From the factory, the breakers/power switches and line cord are both set for 200 VAC use. Depending on where they were last used, used/rented lamp power supplies may be set to either, so check the status of the line cord plug and breakers/power switches before attempting to connect to AC. See instructions below.

⚠ WARNING Servicing should only be done by a Christie accredited service technician.

1. A visual inspection of the plug indicates the status for the 200 or 400 VAC. Change the ballast's plug type necessary for your site, as a delta load with safety ground has no neutral.
2. Remove the ballast cover to access and read the Input Power Range Switch.
3. Toggle the breakers/power switches **left** for use with 200 VAC supplies or **right** for 400 VAC supplies.
4. Attach the ground lug to Earth Ground.
5. Re-install the ballast cover.

See [Section 2.2 Quick Setup](#) for further details.

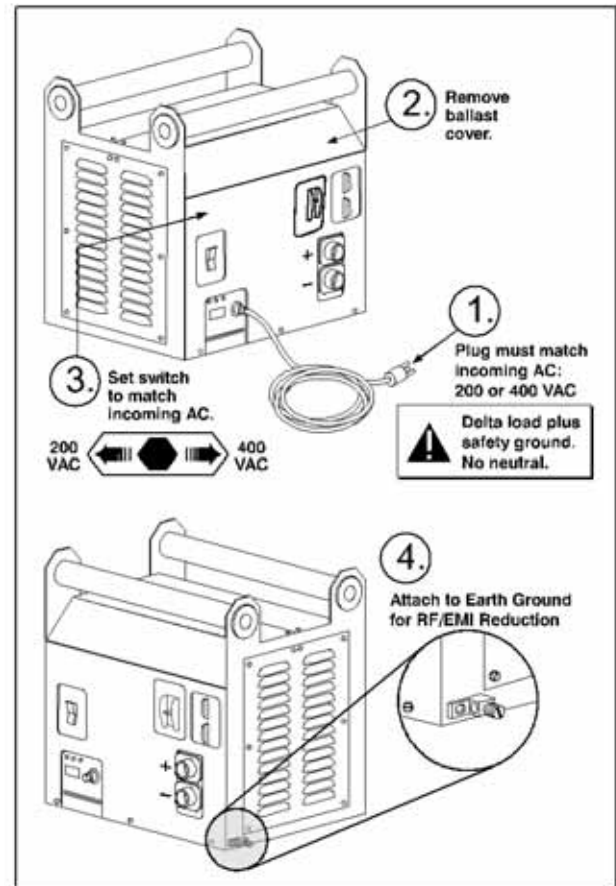

2.7 Basic Image Adjustment

NOTE: Assumes a single projector is powered up in its final location.

This initial optical alignment procedure is the foundation for optimizing your displays, ensuring that images reflected from the DMDs are parallel to and well-centered with both the lens and screen. It should be completed before adjusting the lens boresight.

Before you begin:

Properly position the projector relative to the screen. See [Section 2.3 Projector Position and Mounting](#).

Basic Optical Alignment Procedure

1. Display a test pattern appropriate for analyzing image focus and geometry, such as a single cross hair centered across the image.
2. **Course focus.** Do a quick preliminary (center) focus and (if available) zoom adjustment with the primary lens only. See [Section 3.14 Working with the Lenses](#) in the *Roadie HD+35K User Manual*.
3. **Center the image in the lens.** Holding a piece of paper (full white field) at the lens surface, adjust offsets until the image on the paper is centered within the lens perimeter.
4. **Re-check side-to-side leveling.** With a test pattern on screen, double-check projector leveling (see [Section 2.3 Projector Position and Mounting](#)) so that the top edge of the image is parallel to the **top edge** of the screen.

3 Operation

This section describes how to use the controls and switches for basic projector operation once it is properly installed, aligned and configured by a Christie accredited service technician, as described in *Section 2 Installation and Setup*.

3.1 Projector Basics

Primary Roadie HD+35K components are:

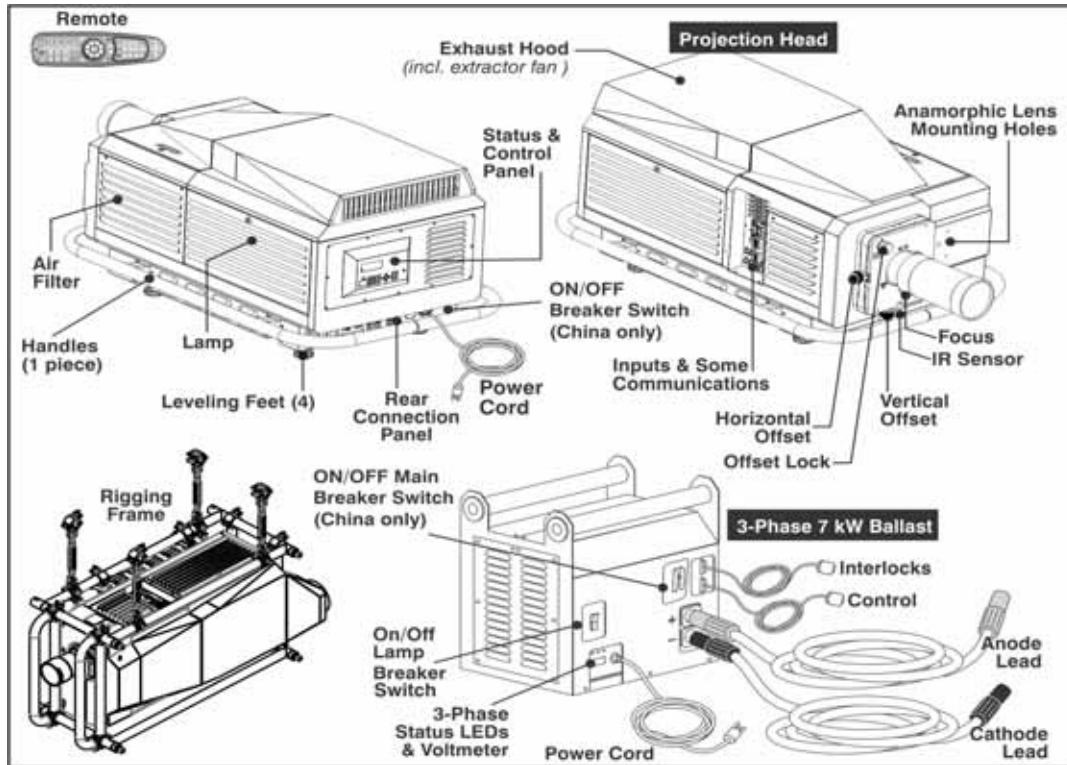

Figure 3-1 Roadie HD+35K Projector and Components

3.1.1 Air Filter

Intake air flows through the filter before circulating in the front compartment to cool main electronics. Replace the air filter whenever the lamp is replaced, or sooner in dusty/dirty environments. See *Section 4.2 Replacing the Lamp and Filter* in the *Roadie HD+35K User Manual* for complete instructions.

IMPORTANT! *Check condition of the air filter every month.*

3.1.2 Breakers/Power Switches (ON/OFF)

The ballast breakers/power switches on the ballast serves two purposes:

1. It is a breaker/power switch for the Roadie HD+35K ballast.
2. It protects against over-current conditions of 50A or more. For China models the rating is 40A or more.

For China models, the projector breaker on the projector head rear panel serves two purposes:

1. It is a breaker/power switch for the Roadie HD+35K projector head.
2. It protects against over-current conditions of 10A or more.

The breakers/power switches must be ON in order to enable normal Roadie HD+35K system power-up and operation. If faulty or major excessive AC is detected, the breakers “trip” to OFF in order to prevent damage. Try switching the breakers/power switches ON again. If the breakers/power switches continues to trip OFF, this indicates a major fault, and the AC problem must be resolved. Possible causes might include shorts, damage to lamp cables, or very excessive AC.

NOTE: You must press **POWER** on the built-in keypad as the breaker/power switch do not power up the projector or start the lamp.

The internal ballast fan indicates whether or not both (Main and Lamp) breakers/power switches are ON. There is no other indicator. When the main ballast breaker is ON, lights on the ballast indicate only that the ballast is plugged in.

3.1.3 Control Panel (Rear of Projector)

The rear control panel includes the built-in keypad, IR sensor, 2-digit status/error code display window, and the LCD status display, as described in [Table 3.1](#).

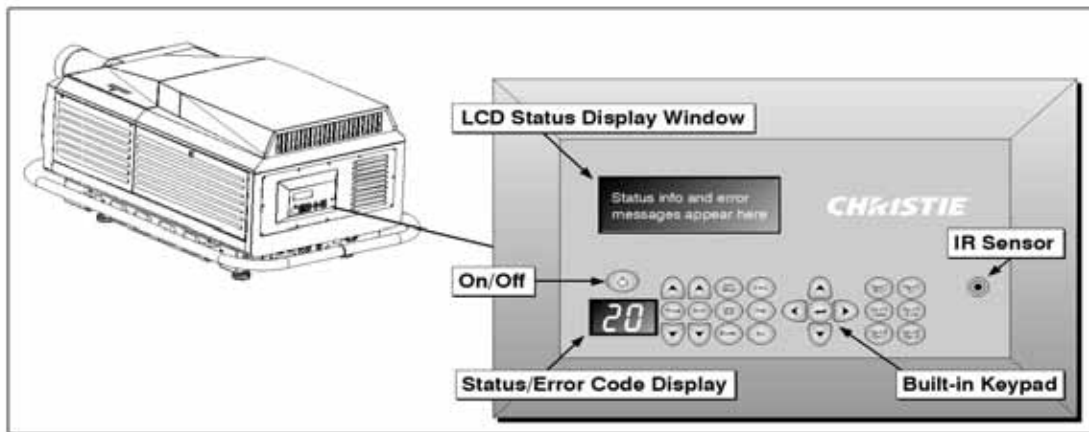

Table 3.1 Rear Projector Control Panel

| CONTROL PANEL AREA | DESCRIPTION |
|---|--|
| Built-In Keypad | PROVIDES ACCESS TO ALL SOFTWARE CONTROLS NEEDED FOR WORKING WITH THE PROJECTOR. FOR MORE CONVENIENT FUNCTIONALITY, YOU CAN USE A REMOTE, WEB BROWSER, OR A SERIAL MESSAGE-BASED METHOD OF CONTROL. |
| IR Sensor | SENSORS AT THE FRONT AND REAR OF THE PROJECTOR DETECT COMMANDS FROM THE STANDARD IR REMOTE. |
| Two-Digit Status/Error Code Window | THE CODE THAT DISPLAYS IN THIS WINDOW INDICATES THE BASIC OPERATIONAL STATE OF THE PROJECTOR. EACH CODE REFERENCES ITS CORRESPONDING STATUS/ ERROR MESSAGE AND DISPLAYS IT IN THE LCD Status Display WINDOW. SEE Section 3.4.1 System Warnings/Errors . |
| LCD Status Display | FULL STATUS AND ERROR MESSAGES APPEAR IN THIS WINDOW. |

3.1.4 Handles

Mounted to the bottom of the projector is the handles assembly, which allows for transportation of the projector over a short distance. The handles can also be used to hoist a single projector only. For rigging purposes, the weight of the projector **must not** exceed 435 lbs. (197.3 kg) including the handles.

NOTE: Any overhead suspension used **MUST** be suitably rated for the weight of the projector.

Installations which require the stacking of projectors must use the FredFrame™. The handles assembly must first be removed to expose the projector's channels, and allow for installation of the FredFrame™.

3.1.5 Channels for FredFrame™

An adjustment mechanism (part of Christie's FredFrame™) that is inserted and secured into the channels located under the projector, enables the projector to be hoisted, flown, and/or stacked. Consult complete installation instructions supplied with the FredFrame™ Kit.

3.1.6 Security Locks

Critical internal components and/or connections are protected by standard medium-security locks. This safeguard helps ensure access by authorized personnel only. Remaining panels are not removable with standard tools, or they are blocked by other obstacles that prevent theft or tampering.

3.2 Using the Built-In Keypad or Remote

The projector is typically controlled using one of the following:

- **The built-in keypad** (Figure 3-2) located at the rear of the projection head
- **The standard IR remote** (Figure 3-3) wired (includes a 100 ft. cable) or wireless control up to 100 feet

While the built-in keypad or standard remote provides complete control of the projector, they differ slightly in their arrangement of keys and in what functions can be accessed directly with a key press, rather than requiring use of the Menu system. You may find the **built-in keypad or the standard IR remote** more convenient for your specific installation and application.

3.2.1 Built-in Keypad

To control the projector when signals from a **standard IR remote** cannot reach the projector, you can use the projector's built-in keypad, located at the rear of the projector. Two nearby windows provide feedback indicating current status and activities of the projector. Because the built-in keypad has fewer keys than the standard IR remote, certain projector functions are accessible only through the **Menu** system.



Figure 3-2 Built-in Keypad at Rear of Projector

3.2.2 Standard IR Remote and Transmission

The Roadie HD+35K comes with a standard IR remote which controls the projector by way of wireless communication from a battery-powered infrared (IR) transmitter. Use the standard IR remote the same way you would use any remote supplied with a TV or DVD player.

When pressing any key, ensure that you direct the remote either toward the screen or toward the front or rear of the projector. One of the two IR sensors on the projector detects the signals and relays the commands for internal processing.

See the key descriptions provided for the standard IR remote (*Figure 3-3*).

3.2.3 Wired IR Remote

Should you require a wired connection, use the cable (100 ft. cable supplied) to connect to the 3-pin XLR jack connector (*Figure 3-3*) located at the rear of the projector. You also need to set the proper internal jumper settings accordingly. The wired standard IR remote is recommended when:

- The rear built-in keypad is inaccessible
- The lighting conditions are unsuitable for proper IR transmission

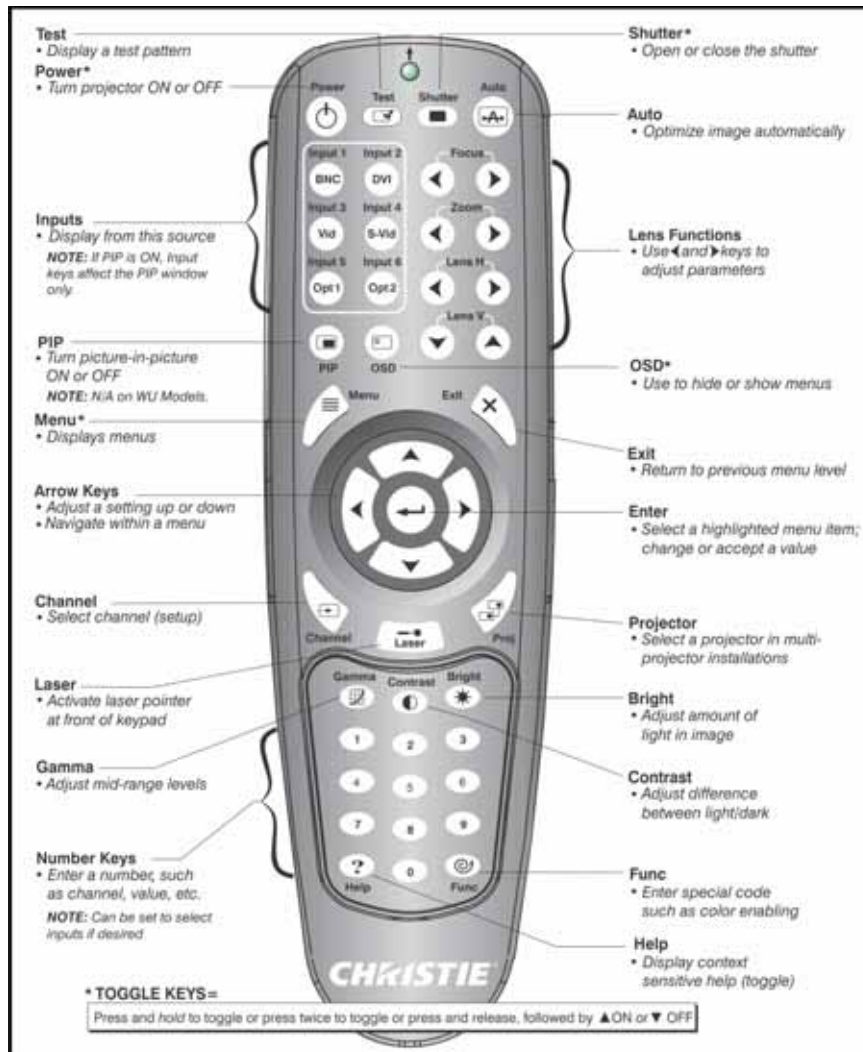

Figure 3-3 Standard IR Remote Keypad

3.3 Power-up Procedure/Checklist

NOTE: This is a typical manual power-up procedure. Some installations may include an automation system that controls projector start-up and lamp ignition in conjunction with other variables such as lighting, audio and other equipment.

⚠ WARNING Do not attempt operation if the AC supply is not within the specified voltage range.

The following steps provide a checklist of steps for the Power-up procedure:

1. Make sure that ballast is properly configured for the AC at your site, and that it is connected via 4 cables to the projection head. See [Section 2.6 Connecting the Ballast](#).
2. Use locking type cord provided to plug in projector head.
3. For China models, turn the projector head breaker ON.

NOTE: At this point, the projection head is in “standby” mode only. The voltmeter displays the incoming voltage, the adjacent main PROJ. STATUS light yellow, and the light engine compartment fans running. The rest of the projection head should be OFF.

4. Connect the ballast's integral three-phase 30-amp line cord to your AC supply according to your site.
5. For China models, turn the ballast main breaker ON.
6. Confirm the ballast's three-phase status lights are ON and the adjacent voltmeter displays an acceptable AC level for your ballast, and region. See [Section 5 Specifications](#) for details.
7. Turn the lamp breaker ON.
8. With the breakers/power switches set to ON. Listen for the internal cooling fan to start-up.

NOTE: There is no other indication of whether the ballast is ON or not.
9. Press **MENU**. The status display at the rear of the projector displays a “Lamp Size” of 2000, 3000, 4500 or 6000 watts, depending on its last setting (factory default=6000). Enter the lamp password.

NOTE: The password is required unless the “Enable Password” service option has been turned OFF.
10. Press **POWER** and use the **UP ARROW** to locate, and select which lamp is currently installed. When the status display shows the correct lamp type, the projector, and lamp can be switched ON.
11. Press and hold the **POWER** button to turn the projection head ON and ignite the lamp. The main PROJ. STATUS light at the rear of the projector should be green when the projector is up-and-running. For best results, let the projector warm up for about 5 minutes.

If the Lamp Does Not Ignite, check:

- If a safety interlock switch is open (such as when the lamp door is ajar), the lamp cannot be struck. The PROJ. STATUS light on the rear of the projector glows red, and an error appears on the status display, and LCD window.
- If the lamp fails to ignite even though the interlock system is OK, the projector automatically tries to re-ignite using 100% of the maximum power acceptable for the installed lamp. If this re-try fails, the lamp likely needs replacement.

NOTE: For complete power-up troubleshooting, See [Section 4 Troubleshooting](#).

12. In the **Lamp** menu, set the “**Cable Length (m)**” to match the length of the DC cables currently connected between your ballast and projection head.

For more information, see [Section 2.2 Quick Setup](#).

3.4 Power-down Procedure

NOTE: *Describes a manual shutdown only. May be automated.*

1. Do one of the following to turn the projection head and lamp off:
 - Press **POWER** twice quickly
 - Press and hold **POWER**
 - Press **POWER + DOWN ARROW**

NOTE: *Continue running all fans, including the heat extractor to cool the lamp for approximately 10 minutes.*

⚠ WARNING **Make sure to wait for the fans to cool completely.**

2. Turn the breakers/power switches **OFF** on both the projector head and ballast.

3.4.1 System Warnings/Errors

When the projector encounters a system malfunction, either a System Warning message or a System Error message may appear. Both types of messages are accompanied by a numerical error code on the “Status” LED and a related text message in the LCD Status Display window. A system malfunction can be cleared by pressing **EXIT** twice from the presentation level, but may indicate the need for service by a Christie accredited service technician.

NOTE: *System messages appear on-screen only if Display Error Messages has been set to “Screen” or “All”.*

For more information, see the *Roadie HD+35K User Manual (P/N: 020-100340-XX)*.

4 Troubleshooting

If the projector does not appear to be operating properly, note the symptoms and use this section as a guide. If the problem cannot be resolved, contact your dealer for assistance.

NOTE: A Christie accredited service technician is required when opening an enclosure to diagnose any "probable cause".

4.1 Projector Does Not Power ON

Check for the following:

- For China models, ensure the projector breaker, main ballast breaker and the lamp breaker are all in the ON position.
- Ensure the display backlight and the LEDs on the built-in keypad are functioning, and if the menu displays. If the built-in keypad is not functioning, it may need to be replaced.

4.2 Lamp

4.2.1 Lamp Does Not Ignite

Check for the following:

- Is there an interlock failure? From the **Status** menu, check the **Alarms** and **Interlocks** secondary menu. From the web user interface, check the **Status > System** menu.
- If there is any indication through the **Status** menu of a ballast communication problem, re-boot the projector and try turning the lamp ON again.
- If a DMD temperature is too high, the lamp will not ignite. Cool the projector and try again. Ensure there is proper ventilation. If an optional exhaust is used, ensure it has adequate airflow.
- If the lamp does not ignite after the second attempt, replace the lamp.
- Listen for a "clicking" noise to indicate the ballast is attempting to strike the lamp. If not, it may indicate a problem with the ballast (a Christie accredited service technician is required to resolve the issue).
- If you hear a brief "click", but no light appears, the lamp likely needs replacement.

4.2.2 Lamp Suddenly Goes OFF

Check for the following:

- Check lamp power through the **Lamp** menu or web user interface **Advanced > Lamp** menu.
- Try increasing lamp power.
NOTE: Older lamps may not reliably operate at significantly lower than rated power.
- The DMDs may be overheated. Check for an alarm condition.
- An interlock may be interrupting lamp function.
- If none of these checks resolves the issue, the lamp likely needs replacement.

4.2.3 Flicker, Shadows Or Dimness

Check for the following:

- Ensure the shutter is open.

- LampLOC™ may need re-adjustment.
- LampLOC™ may be in the middle of its adjustment. Wait approximately 2-3 minutes.
- Adjust LampLOC™ motors manually, via the **Main menu**. Confirm all stepper motors are operational by watching on screen with a full white test pattern while adjusting.
- Increase lamp power, if possible. Lamps which are near end of life may not operate reliably at lowest power range.
- Fold mirror misalignment (a Christie accredited service technician is required to resolve the issue).

4.2.4 LampLOC™ Does Not Seem to Work

Check for the following:

- If the **Do Auto** LampLOC™ function does not work, try adjusting the lamp position manually, via the **LampLOC > Manual Adjust** menu. Observe screen brightness by adjusting the XYZ values or use a light meter to check for changes in brightness.
 - Use a Minolta™ T10 illuminance meter (hand-held): Position meter in center of screen to take reading.
 - OR-
 - Use a Minolta™ LS-100 luminance meter: Point the lens at the center of the screen to take a reading. Retake the reading each time an adjustment is made.
- Always adjust XY values before adjusting Z values. Repeat XY adjustments any time Z is adjusted. If brightness levels are not changing when adjusting the XYZ motors it is likely 1 of the motors is damaged, the stepper driver board has malfunctioned or there is a faulty connection.

4.2.5 LiteLOC™ Does Not Seem to Work

Check for the following:

- Ensure LiteLOC™ is set and enabled in the **Lamp** menu.
- If the lamp power has reached its maximum setting, the light intensity reading still cannot meet the target; however, it appears it is not functioning. For example, if the lamp power range is from 1kW (light intensity reading 4000) to 3kW (light intensity reading 6000) and the light intensity is set to 10,000 it will never find the maximum lamp power level because the light intensity is set too high. In this case, simply reduce the LiteLOC™ value within (4000, 6000).

4.3 Calibrating the Lens Mount

The lens mount must be calibrated when:

- A new lens has been installed
- The lens mount has been replaced
- Lens settings are drifting within a short period of time

⚠ CAUTION

Lens calibration must be performed each time a new lens is inserted or after performing manual lens mount adjustments. To calibrate the lens, select the Configuration > Diagnostics and Calibration > ILS Calibration > Reference Calibration option from the Main menu. This is critical to the projector functioning properly. Failure to do so could result in damage to the lens mount, the projector, or the projection lens.

4.4 Built In Keypad

4.4.1 Projector ON, but No Backlight on Built-In Keypad

Check the following:

- Confirm the harness is plugged into the back of the built-in keypad (via the lamp compartment door).
- Touch any key. The backlight for the displays and keys should be present.

4.5 Image Displays

The following troubleshooting entries assume the use of a third-party input source. Before proceeding, consult the documentation supplied with the external equipment.

4.5.1 Blank Screen, No Display of Image

Check the following:

- Confirm all connections are OK.
- Ensure the lens cap is not on the lens.
- Ensure the shutter is OPEN. Press **SHUTTER OPEN** on the standard IR remote or built-in keypad to open.
- Ensure a full black test pattern **IS NOT** selected for display.

4.5.2 Severe Motion Artifacts

Most likely there is a synchronization problem with reversed 3-2 drop-down in 60 to 24 Hz film-to-digital conversion in your source. The display file needs correction.

4.5.3 Image Appears Vertically Stretched or ‘Squeezed’ into Center of Screen

Source data converted from film and “pre-squeezed” for Roadie HD+35K display format may require use of an anamorphic lens (or resizing) to regain full “scope” image width and proper proportions.

4.5.4 The Projector is ON, but There is No Display

Check the following:

- Ensure the lens cap is not on the lens.
- Ensure shutter is OPEN.
- If the lamp is not ignited, press **LAMP ON** from the standard IR remote or built-in keypad.
- Ensure AC power is connected and power switch is ON.
- Is an active source connected properly? Check the cable connections and ensure the alternative source is selected.
- Can you access test patterns? If so, check source connections again.

4.5.5 The Display is Jittery or Unstable

Check the following:

- If the image display is jittery or blinking erratically, ensure the source is properly connected and of adequate quality for detection. With a poor quality or improperly connected source, the projector will repeatedly attempt to display an image, however briefly.
- The horizontal or vertical scan frequency of the input signal may be out of range for the projector.
- The sync signal may be inadequate. Correct the source problem.

4.5.6 The Display is Faint

Check the following:

1. The source may be double terminated. Ensure the source is terminated only once.
2. The source (if non-video) may need sync tip clamping.

4.5.7 The Upper Portion of the Display is Waving, Tearing or Jittering

This can occur with video or VCR sources. Check your source.

4.5.8 Portions of the Display are Cut OFF or Warped to the Opposite edge

Resizing may need adjustment. Adjust until entire image is visible and centered.

4.5.9 Display Appears Compressed (Vertically Stretched)

Check the following:

- The frequency of the pixel sampling clock is incorrect for the current source.
- Sizing and positioning options may be adjusted poorly for the incoming source signal.
- Use an anamorphic lens for typical HDTV and anamorphic DVD sources that have been re-sized and vertically stretched, via 3rd-party software.

4.5.10 Data is Cropped from Edges

To display the missing material, reduce image size to fill the display area available in the projector, then stretch vertically to fill the screen from top to bottom. Add the anamorphic lens to regain image width, if required.

4.5.11 Display Quality Appears to Drift from Good to Bad, Bad to Good

Check the following:

- The source input signal may be of low quality.
- The H or V frequency of the input may have changed at the source end.

4.5.12 Display has Suddenly Froze

If the screen blacks out inexplicably, it is possible excessive voltage noise on the AC or ground input has interrupted the projector's ability to lock on to a signal. Power down and up again.

4.5.13 Colors in the Display are Inaccurate

The color, tint, color space and/or color temperature settings may require adjustment at your input source, or in the projector.

4.5.14 Display is Not Rectangular

Check the following:

- Check leveling of the projector.
- Ensure the lens surface and screen are parallel to one another.
- Ensure the keystone setting is properly set.

4.5.15 Display is “Noisy”

Check the following:

- Display adjustment at the input source may be required. Adjust pixel tracking, phase and filter. Noise is particularly common on YPbPr signals from a DVD player.
- Ensure the video input is terminated (75 Ω). If it is the last connection in a loop-through chain, the video input should be terminated at the last source input only.
- The input signal and/or signal cables carrying the input signal may be of poor quality.
- If the distance between the input source device and the projector is greater than 25 feet, signal amplification/conditioning may be required.
- If the source is a VCR or off-air broadcast, detail may be set too high.

5 Specifications

This section provides detailed Roadie HD+35K specifications. Due to continuing research, specifications are subject to change without notice.

5.1 Display

5.1.1 Panel Resolution and Refresh Rate

| | |
|--------------------------------|--|
| PIXEL FORMAT (H x V) ON 3 DMDs | 2048 x 1080 |
| REFRESH RATE, 2D DISPLAYS | 23.97 - 65 Hz |
| REFRESH RATE, FRAME-DOUBLED 3D | 23.97 - 96 Hz |
| INPUT-TO-IMAGE DELAY | 2 FRAMES +30 LINES (IF LOCKED TO INPUT) 3 FRAMES (NO TIMING RESTRICTIONS) |

5.1.2 Achievable Brightness

Typical output using CDXL lamps:

- If 2.0 kW lamp: 12,000 ANSI lumens (13,000 Center lumens)
- If 3.0 kW lamp: 18,000 ANSI lumens (19,500 Center lumens)
- If 4.5 kW lamp: 27,000 ANSI lumens (29,000 Center lumens)
- If 6.0 kW lamp: 32,500 ANSI lumens (35,000 Center lumens)

5.1.3 Achievable Contrast Ratio

With CDXL lamp and standard optical aperture installed:

- With standard high-brightness lens: 2000:1 full field
- With optional high-contrast lens: 2800:1 full field

5.1.4 Colors and Gray Scale

| | |
|---------------------------------------|--------------------------------|
| DEFAULT COLOR TEMPERATURE | 6500K +950K/-650K |
| RANGE OF COLOR TEMPERATURE ADJUSTMENT | 3200K - 9300K |
| DISPLAYABLE COLORS | 1.1 BILLION |
| GRAY SCALE RESOLUTION | 10 BITS EACH PER RGB COMPONENT |

5.1.5 Gamma

Adjustable from 1.8 - 2.8 (default = 2.2 ±0.4)

5.2 Lenses

IMPORTANT! For proper placement in any installation, use the lens and screen size to calculate the precise throw distance using the tables provided in the Dealer Section of the Christie Website, PN 020-100395-xx. In addition, please keep in mind that due to lens manufacturing tolerances for lens focal length, actual throw distance can vary $\pm 5\%$ or more between lenses described as having the same throw ratio.

5.3 Inputs

TOTAL NUMBER OF STANDARD INPUTS 6 (INCLUDING DUAL SD/HD-SDI).

NOTE: Not applicable with all models.

- Analog: RGB / YPbPr (5 BNCs at INPUT 1)
- Analog: Video (INPUTS 3 and 4)
- Analog: Sync (Interlaced or Progressive Scan Format)
- DVI-I (INPUT 2)
- Dual SD/HD-SDI (INPUT 5 or 6, Standard with Projector)

5.4 Control

5.4.1 Wired Remote

| | |
|-----------------------------|---|
| 2 INPUTS ON PROJECTION HEAD | <ul style="list-style-type: none"> • 3-pin XLR connector (rear) • 3.5mm phono jack (side) |
| INPUT LEVELS | <ul style="list-style-type: none"> • High = 2.2 V – 5.6 V (or open) • Low = -0.6 V – 0.9 V @ 1 mA |
| VOLTAGE OUTPUT | +5VDC $\pm 5\%$ |
| CURRENT OUTPUT | 100 mA NOMINAL, 250 mA MAX. |
| CABLE LENGTH | 25 FT. |

5.4.2 Remote Control

| | |
|-----------------------------------|------------------------|
| NUMBER OF IR SENSORS ON PROJECTOR | 2 (FRONT AND REAR) |
| WAVELENGTH OF PEAK SENSITIVITY | 1000 NM (APPROX.) |
| MODULATION (CARRIER) FREQUENCY | 38 KHZ (NOMINAL) |
| ENCODING METHOD | BI-PHASE |
| RANGE | 100 FT. 50 FT. MIN. |

Assumes no fluorescent lighting interference.

If range appears limited, shield the IR sensor, turn off lights, or change your fluorescent ballast.

5.4.3 Ethernet

| | |
|-----------------|------------|
| NUMBER OF PORTS | 1 |
| STANDARD | 100BASE-TX |
| CONNECTOR TYPE | RJ-45 |
| MAX. BAUD RATE | 115200 |

5.4.4 RS-232 Serial Input

| | |
|----------------------|---|
| NUMBER OF CONNECTORS | 2 |
| CONNECTOR TYPE | 9-PIN SUBMINIATURE D (FEMALE = IN, MALE = OUT) |
| MAX. BAUD RATE | 115200 |

5.4.5 RS-422 Serial Input

| | |
|---------------------------------------|--------------------------|
| NUMBER OF CONNECTORS | 2 |
| CONNECTOR TYPE (SIDE INPUT PANEL) | 1 X 9-PIN SUBMINIATURE D |
| CONNECTOR TYPE (REAR CONNECTOR PANEL) | 1 X 6-PIN XLR |
| MAX. BAUD RATE | 115200 |

5.4.6 GPIO Input

| | |
|--|---------------------------------------|
| NUMBER OF I/O LINES | 7, EACH ASSIGNABLE AS INPUT OR OUTPUT |
| CONNECTOR TYPE | 9-PIN SUBMINIATURE D (MALE) |
| TYPE OF CONNECTION | DRY CONTACT |
| OUTPUT SINK CURRENT (<i>LOGIC LOW</i>) | 100 MA @ 1V |
| MAXIMUM POWER OUTPUT | +12VDC @ 200 MA |

NOTE: SHARED WITH 9-PIN RS422 PORT.

5.4.7 Control Port (From Ballast)

| | |
|----------------------|-----------------------------|
| NUMBER OF CONNECTORS | 1 |
| INTERFACE | RS232 |
| CONNECTOR TYPE | 9-PIN SUBMINIATURE D (MALE) |

5.4.8 Ballast Ports

| | |
|----------------------------|--|
| NUMBER OF CONNECTORS | 1 |
| INTERFACE | +5 V TTL-COMPATIBLE NOTE: <i>Opto-isolated at ballast end.</i> |
| CONNECTOR TYPE | 9-PIN SUBMINIATURE D (FEMALE) |
| NUMBER AND TYPE OF OUTPUTS | 1 – LAMP ENABLE (LOW = ENABLE LAMP) 4 – SAFETY INTERLOCKS (HIGH = DISABLE LAMP) 1 – +5 VDC FOR OPTO-ISOLATED INTERFACE |

5.5 Power

5.5.1 Projection head

Projection Compartment AC (near Panel B, at front)

| | |
|---------------------------|-------------------------------------|
| CONNECTOR TYPE AND RATING | (1) IEC 320-COMPATIBLE, 10 A RATING |
| VOLTAGE RANGE, NOMINAL | 200 – 240 VAC ±10% |
| LINE FREQUENCY, NOMINAL | 50 – 60 Hz |
| AC INPUT RATING | 10 A |
| BREAKER/POWER SWITCH | 10 A |
| MAX. INRUSH CURRENT | 35 A |
| MAX. CURRENT CONSUMPTION | 3 A |
| MAX. POWER CONSUMPTION | 700 W |

Lamp (DC)

| | |
|--------------------------|--|
| MAX. OPERATING VOLTAGE | 46 VDC |
| MAX. START-UP VOLTAGE | 155 VDC |
| MAX. CURRENT CONSUMPTION | 180 A |
| MAX. POWER CONSUMPTION | 6600 W |
| CONNECTOR TYPE | FEMALE CAM LOCK RECEPTACLE (+RED) MALE CAM LOCK RECEPTACLE (–BLACK) |

5.5.2 7 kW 3-Phase Ballast (38-814001-51)

| | |
|---|--|
| INPUT RATINGS | 200-230 V 3~ +PE, 24 A, 50-60 Hz/380-415V 3~ +N +PE, 16 A, 50-60 Hz |
| INRUSH CURRENT (MAX.) <i>NOTE: EXCLUDING LAMP</i> | <50 A |
| POWER CONSUMPTION (MAX.) | 14.4 kVA (9.1 kW), ALL REGIONS |
| CURRENT RATING (CONTINUOUS) OF 3-PHASE AC INPUT AT BREAKERS/POWER SWITCHES | 30 A, ALL REGIONS |
| BREAKER/POWER SWITCH RATING | 50 A |
| CHINA BREAKERS/POWER SWITCHES RATING | 40 A |
| Ballast Output to Projection Head | |
| OPERATING VOLTAGE RANGE | 25-46 VDC |
| START-UP VOLTAGE (OPEN CURRENT) | 125-155 VDC |
| OPERATING CURRENT RANGE | 50-180 A |
| RIPPLE | 1% MAX @ 25°C |
| CONTROL PORTS | SEE 5.4.7 Control Port (From Ballast) AND 5.4.8 Ballast Ports ON PREVIOUS PAGE. |

5.6 Lamps

Replace before:

| BALLAST | CXL/CDXL LAMPS (KW) | LAMP LIFE (HRS.) |
|---------------------|---------------------|------------------|
| 3-Phase 7 kW | CXL/CDXL-20 (2.0) | 3000 |
| | CXL/CDXL-30 (3.0) | 2000 |
| | CXL/CDXL-45 (4.5) | 600 |
| | CXL/CDXL-60 (6.0) | 600 |

NOTES: 1) Current range shown includes “over-drive”, which is 10% more than the original lamp rating.
 2) Optimized brightness requires CDXL lamp.

| TYPE | XENOLITE® |
|---------------------------------------|--------------------------------------|
| STAND-BY LAMP POWER LEVEL FOR 4.5/6.0 | 60% OF LAMP’S MAXIMUM CURRENT RATING |
| STAND-BY LAMP POWER LEVEL 2.0/3.0 | 75% OF LAMP’S MAXIMUM CURRENT RATING |
| MOTORIZED ADJUSTMENT OF POSITION | 3-AXIS, 0.25” RANGE FOR EACH |

5.7 Safety

- CAN/CSA C22.2 No. 60950-1-07
- UL 60950-1
- IEC 60950-1

5.8 EMC Emissions

- FCC CFR47, Part 15, Subpart B, Class A – Unintentional Radiators
- CISPR 22: EN55022: Class A – Radio disturbance characteristics for Information Technology Equipment (ITE)

5.9 EMC Immunity

CISPR 24/ EN55024: All parts for immunity characteristics for Information Technology Equipment (ITE)

5.10 Operating Environment

| | |
|---------------------------|-------------------------|
| Temperature | 10 to 35°C (50 to 95°F) |
| Humidity (non-condensing) | 20 to 80% |
| Altitude | 0 – 3000 meters |
| Tilt, any angle | 15 degrees max. |

5.11 Non-Operating Environment

| | |
|---------------------------|----------------------------|
| TEMPERATURE | -25 TO 65°C (-13 TO 149°F) |
| HUMIDITY (NON-CONDENSING) | 0 TO 95% |

5.12 Weight and Size

NOTE: 1) Dimensions exclude lens and cabling. **2)** Installed projector weight assumes the heaviest lens, lamp and all accessories are installed. **3)** All weights and dimensions subject to change.

5.12.1 Standard Dimensions

| | |
|---|--|
| PRODUCT DIMENSIONS (W X L X H) WITHOUT LENS (INCLUDING FEET AT MINIMUM HEIGHT POSITION) AND WITHOUT HANDLES | 1257 MM X 684 MM X 577 MM 49.5" X 26.5" X 22.7" |
| PRODUCT DIMENSIONS (W X L X H) WITHOUT LENS (INCLUDING FEET AT MINIMUM HEIGHT POSITION) AND HANDLES | 1362 MM X 800 MM X 577 MM 53.6" X 31.5" X 22.7" |
| PACKAGING DIMENSIONS (W X L X H), SHIPPED WITHOUT LENS ATTACHED | 1650 MM X 1040 MM X 890 MM 65" X 41" X 35" |

Shipping Weights

| | |
|-----------------|-------------------|
| PROJECTION HEAD | 460 LB (209.1 KG) |
| BALLAST | 145 LB (66 KG) |
| FREDFRAME™ | 166 LB (76 KG) |

Installed Weight

| | |
|-----------------|-------------------|
| PROJECTION HEAD | 435 LB (197.3 KG) |
| BALLAST | 110 LB (50 KG) |
| FREDFRAME™ | 110 LB (50 KG) |

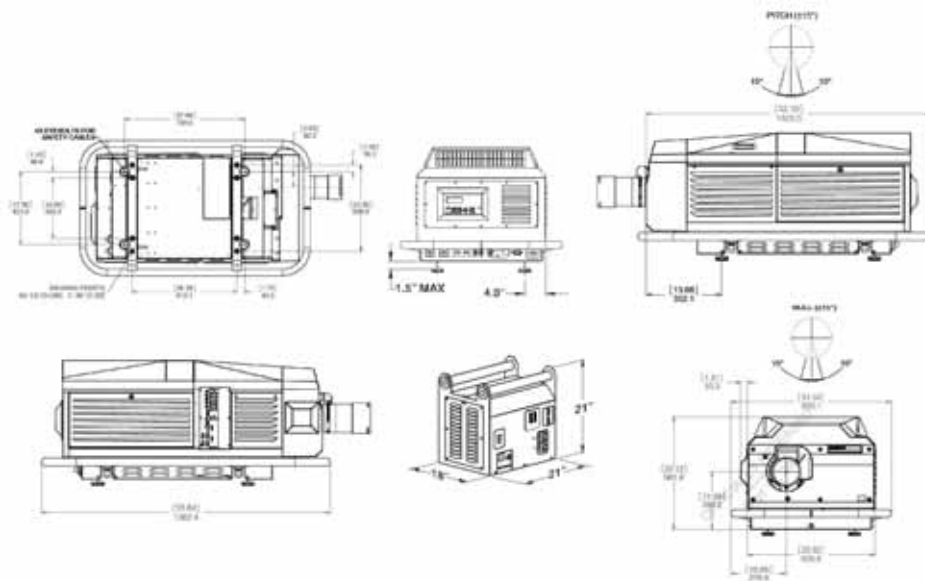

Figure 5-1 Overall Size Dimension

5.13 Standard and Optional Components

5.13.1 Standard (Sold with Product)

- Projection head with built-in keypad and standard IR remote (configured for IR operation, batteries included)
- 25 ft cable for conversion of standard IR remote to wired operation
- Line Cord, 10-foot
- Face shield (required for lamp handling)
- Dual SD/HD-SDI input module (38-804656-xx)
- Roadie HD+35K User Manual
- Misc. hardware, including Allen Keys

5.13.2 Optional (Sold Separately)

Projection Lenses

The projection head is compatible with the following optional lenses:

| | |
|------------------------------|---------------|
| 0.8:1 FIXED THROW RATIO LENS | 113-104106-XX |
| 1:1 FIXED THROW RATIO LENS | 38-809071-XX |
| 1.25 – 1.45:1 | 38-809073-XX |
| 1.45 – 1.8:1 | 38-809074-XX |
| 1.8 – 2.4:1 | 38-809075-XX |

| | |
|---|--|
| 2.2 – 3.0:1 | 38-809076-XX |
| 3.0 – 4.3:1 | 38-809077-XX |
| 4.3 – 6.0 :1 | 38-809072-XX |
| 5.5 – 8.5 :1 | 38-809078-XX |
| MOTORIZED AUXILIARY LENS MOUNT | 38-813019-XX |
| 1.26X ANAMORPHIC LENS | 38-809054-XX |
| Lamp Power Supplies | |
| REMOTE BALLAST (7 kW) | 38-814001-XX |
| Ballast (Remote) Cable Kits | |
| 2 METERS (6.5 FT.) | 38-814003-XX |
| 7.5 METERS (25 FT.) | 38-814004-XX |
| 15 METERS (50 FT.) | 38-814005-XX |
| 30 METERS (100 FT.) | 38-814006-XX |
| Other | |
| Remote IR Sensor - communication cables | Ethernet, RS-232, and RS-422 |
| Compact/Lite remote | 03-900566-XX |
| Christie TWIST Module for arbitrary image warping and edge blending | 108-103001-XX |
| FREDFRAME™ Rigging Frame | 38-814007-XX |
| Rigging Clamps for flying projection head by handles | 113-102101-XX |
| 10-Bit KoRE Librarian Setup Software | WEBSITE DOWNLOAD (PASSWORD REQUIRED) |
| High-contrast internal aperture kit | 38-813028-XX |
| Analog and Digital Input Modules | SEE APPENDIX D: OPTIONAL INPUT MODULES IN THE ROADIE HD+35K USER MANUAL (P/N: 020-100340-XX) |
| Xenon Lamp | 2 kW, 3 kW, 4.5 kW, and 6 kW |

Corporate offices

USA – Cypress
ph: 714-236-8610
Canada – Kitchener
ph: 519-744-8005

Worldwide offices

United Kingdom
ph: +44 118 977 8000
France
ph: +33 (0) 1 41 21 00 36
Germany
ph: +49 2161 664540

Eastern Europe
ph: +36 (0) 1 47 48 100
Middle East
ph: +971 (0) 4 299 7575
Spain
ph: + 34 91 633 9990

Singapore
ph: +65 6877-8737
Beijing
ph: +86 10 6561 0240
Shanghai
ph: +86 21 6278 7708

Japan
ph: 81-3-3599-7481
South Korea
ph: +82 2 702 1601